

V10 Benchtop Bandsaw Manual



LAGUNA



LAGUNA TOOLS
744 Refuge Way, Suite 200
Grand Prairie, TX 75050
Ph : 1-800-234-1976
www.lagunatools.com

*machine shown with optional accessories

Revision: R01 V02 05/11/2026 Part No. MBAND10V10

© 2025 Laguna Tools, Inc. All rights reserved.

DEAR WOODWORKER

Thank you for your purchase and welcome to the Laguna Tools group of discriminating woodworkers. We understand that you have a choice of where to purchase your machines and appreciate the confidence you have in our products.

Every machine sold by Laguna Tools has been carefully designed and well thought through from a woodworker's perspective. Our machines are used by woodworkers, helping drive continuous improvement to inspire the creation of masterpieces. We work hard to make our machines better, and we strive to give you machines that inspire you to create works of art. Machines that are a joy to run and work on. Machines that encourage your performance.

Today, we offer high-performance machines with innovative solutions that meet the needs of woodworkers and their ever-evolving craft.

Here at Laguna Tools, we are woodworkers.

Thank you again for becoming a Laguna Tools customer.

Laguna Tools

Thriving on Innovation

SAVE THIS MANUAL. Keep this manual for the safety warnings, precautions, assembly, operating, inspection, and maintenance procedures. Read this Owner's Manual in its entirety prior to assembly or operation. Refer to www.lagunatools.com for the latest manual revision.

Read and understand all warnings and operation instructions before using any tool or equipment. Always follow basic safety precautions to reduce the risk of personal injury. Improper operation, maintenance, or modification of tools or equipment could result in serious injury or property damage. Laguna Tools equipment is designed for specific and limited applications. This product should not be modified nor used for any application other than its intended use.

PERSONAL SAFETY IS THE RESPONSIBILITY OF THE OPERATOR

Intended Use

The machine is designed to cut wood and wood-fiber composites. Do not use this machine for anything other than its intended use.

English	French
<p>WARNING: For your own safety, read instruction manual before operating band saw</p> <ol style="list-style-type: none"> 1. Wear eye protection. 2. Do not remove jammed cut off pieces until blade has stopped . 3. Maintain proper adjustment of blade tension, blade guides and thrust bearings . 4. Adjust upper guide to just clear workpiece. 5. Hold workpiece firmly against table . 6. ALWAYS USE A PUSH STICK. Never allow your hands/ fingers to come close to the bandsaw blade. 	<p>AVERTISSEMENT: Pour votre securite, lisez le manuel d'instruction attentivement avant d'utiliser la scie a rub an .</p> <ol style="list-style-type: none"> 1. Portez des lunettes de protection . 2. Ne tentez pas d'enlever une piece coincée avant l'arret complet de la lame. 3. Assurez-vous que les guides et la tension sur la lame soient toujours correctement ajustés. 4. Ajustez la hauteur du guide superieur de façon à passer juste au-dessus de la piece . 5. Tenez la piece fermement sur la table. 6. UTILISEZ TOUJOURS UN POUSSOIR - N'approchez jamais vos doigts, ou vos main, de la lame .
<p>Safety Rules</p>	<p>Regles de securite</p>
<ol style="list-style-type: none"> 1. KEEP GUARDS IN PLACE and in working order. 2. REMOVE ADJUSTING KEYS AND WRENCHES. Form habit of checking to see that keys and adjusting wrenches are removed from tool before turning it on. 3. KEEP WORK AREA CLEAN. Cluttered areas and benches invite accidents. 4. DON'T USE IN DANGEROUS ENVIRONMENT. Don't use power tools in damp or wet locations or expose them to rain. Keep work area well lighted. 5. KEEP CHILDREN AWAY. All visitors should be kept safe distance from work area. 6. MAKE WORKSHOP KID PROOF with padlocks, master switches or by removing starter keys. 7. DON'T FORCE TOOL. It will do the job better and safer at the rate for which it was designed. 8. USE RIGHT TOOL. Don 't force tool or attachment to do a job for which it was not designed . 9. USE PROPER EXTENSION CORD. Make sure your extension cord is in good condition . When using an extension cord, be sure to use one heavy enough to carry the current your product will draw. An undersized cord will cause a drop in line voltage, resulting in loss of power and overheating. Table A shows the correct size to use depending on cord length and nameplate ampere rating. If in doubt, use the next heavier gage. The smaller the gage number, the heavier the cord. 10. WEAR PROPER APPAREL. Do not wear loose clothing, gloves, neckties, rings, bracelets or other jewelry that may get caught in moving parts. Nonslip footwear is recommended . Wear protective hair covering to contain long hair. 11. ALWAYS USE SAFETY GLASSES. Also use face or dust mask if cutting operation is dusty. Everyday eyeglasses only have impact-resistant lenses; they are NOT safety glasses. 	<ol style="list-style-type: none"> 1. CONSERVEZ TOUSLES DISPOSITIFS DE PROTECTION EN PLACE et en bon etat de fonctionnement . 2. ENLEVEZ LES CLES ET OUTILS. Prenez l'habitude de verifier si les clees et autres outils ne sont pas trop pres de la machine avant de la demarrer. 3. CONSERVEZ LA SURFACE DE TRAVAIL PROPRE ET LIBRE D'ENTRAVES. Les endroits encombrés augmentent le risque d'accident . 4. NE PAS UTILISER DANS LES ENVIRONNEMENTS DANGEREUX. N'utilisez pas d'outils electriques dans les endroits humides, detrempés, ou sous la pluie. Conservez l'espace de travail bien eclaire. 5. TENEZ LES ENFANTS A L'ECART. Tousles visiteurs doivent etre tenus à une distance securitaire de l'aire de travail. 6. RENDEZ L'ATELIER A L'EPREUVE DES ENFANTS avec des verrous, des interrupteurs principaux ou en enlevant les clees de demarrage sur les outils. 7. NE FORCEZ PAS L'OUTIL. L'outil effectuera un meilleur travail et de façon securitaire s'il est utilise au rythme pour lequel il a ete concu. 8. UTILISEZ L'OUTIL APPROPRIE. Ne forcez pas un outil ou un accessoire pour effectuer un travail pour lequel il n'a pas ete concu. 9. UTILISEZ UNE RALLONGE ELECTRIQUE APPROPRIEE. Assurez-vous que votre rallonge electrique est en bon etat et que le calibre du filage soit adequat pour transporter le courant que la machine a besoin . Une rallonge de trop faible calibre induira une perte d'intensite du voltage, ce qui provoquera une surchauffe et une perte de puissance . Le tableau A indique le bon calibre à utiliser en fonction de la longueur de la rallonge et de la demande en intensite du moteur. En cas de doute, utilisez la rallonge de calibre plus fort . Plus le numero est petit , plus la rallonge est de fort calibre.

12. SECURE WORK. Use clamps or a vise to hold work when practical. It's safer than using your hand, and it frees both hands to operate tool.
13. DON'T OVERREACH. Keep proper footing and balance at all times.
14. MAINTAIN TOOLS WITH CARE. Keep tools sharp and clean for best and safest performance. Follow instructions for lubricating and changing accessories.
15. DISCONNECT TOOLS before servicing, when changing accessories such as blades, bits and cutters.
16. REDUCE THE RISK OF UNINTENTIONAL STARTING. Make sure switch is in off position before plugging in.
17. USE RECOMMENDED ACCESSORIES. Consult the owner's manual for recommended accessories. The use of improper accessories may cause risk of injury to persons.
18. NEVER STAND ON TOOL Serious injury could occur if the tool is tipped or if the cutting tool is unintentionally contacted.
19. CHECK DAMAGED PARTS. Before further use of the tool, a guard or other part that is damaged should be carefully checked to determine that it will operate properly and perform its intended function - check for alignment of moving parts, binding of moving parts, breakage of parts, mounting and any other conditions that may affect its operation . A guard or other part that is damaged should be properly repaired or replaced.
20. DIRECTION OF FEED. Feed work into a blade or cutter against the direction of rotation of the blade or cutter only.
21. NEVER LEAVE TOOL RUNNING UNATTENDED TURN POWER OFF. Don't leave tool until it comes to a complete stop.

10. PORTEZ DES VETEMENTS APPROPRIES. Ne portez pas de vetements amples, des gants, des colliers, des bracelets, ou tout autre bijou ou accessoire qui pourrait etre entraine par des pieces mobiles . Des souliers a semelle antiderapante sont egalement recommandes . Attachez les cheveux longs et portez un bonnet pour contenir la chevelure trop abondante.
11. PORTEZ DES LUNETTES DE PROTECTION. Portez egalement un masque contre la poussiere si le travail execute degage de la poussiere. Veuillez prendre note que les lunettes de prescription ordinaire ne resistent pas aux impacts et qu'elles ne sont pas homologuees a titre de lunettes de securite.
12. IMMOBILISEZ VOTRE TRAVAIL. Utilisez des serres ou un etau pour immobiliser votre travail lorsque c'est possible. C'est plus securitaire que d'utiliser votre main, et cela permet de liberer vos deux mains pour operer l'outil confortablement.
13. NE VOUS ETIREZ PAS AU-DESSUS DE LA MACHINE. Demeurez solidement en equilibre sur vos pieds en tout temps.
14. ENTRETENEZ LES OUTILS AVEC SOIN. Gardez les outils de coupe tranchants et propres pour en tirer les meilleures performances. Suivez les instructions du fabricant pour la lubrification et l'entretien des accessoires .
15. DEBRANCHEZ LES OUTILS avant d'en effectuer l'entretien ou lors du changement d'accessoires tels que lames ou couteaux.
16. REDUISEZ LES RISQUES DE DEMARRAGE NON INTENTIONNEL. Assurez-vous que l'interrupteur est en position fermee avant le branchement d'un outil.
17. UTILISEZ LES ACCESSOIRES RECOMMANDES. Consultez le manuel d'instruction pour connaitre les accessoires recommandes. L'utilisation d'accessoires inappropriés pose des risques de blessures aux utilisateurs .
18. NE VOUS TENEZ JAMAIS DEBOUT SUR UNE MACHINE. Des blessures graves pourraient survenir si la machine bascule ou si les outils coupants sont touches accidentellement .
19. VERIFIEZ LES PIECES ENDOMMAGEES. Avant de poursuivre l'utilisation d'un outil, tout dispositif de protection ou toute piece endommagee devra etre inspecte pour determiner si elle peut fonctionner correctement et selon l'utilisation qui en est prevue . Verifiez l'alignement des pieces mobiles a savoir s'il ya blocage, un bris, ou toute autre condition qui nuirait a son utilisation . Une piece ou un protecteur endommage doit etre repare ou remplace.
20. SENS D'ALIMENTATION. Alimenter la piece vers la lame ou le couteau dans le sens contraire de sa rotation seulement.
21. NE LAISSEZ JAMAIS UN OUTIL FONCTIONNER DANS SURVEILLANCE - ETEIGNEZ L'OUTIL. Ne laissez pas l'outil sans surveillance jusqu'a ce qu'il s'arrete completement .

Ampere Rating		Volts	Total length of cord in feet			
		120	25	50	100	150
		240	50	100	200	300
More Than	Not More Than		Minimum gage for cord			
0	6		18	16	16	14
6	10		18	16	14	12
10	12		16	16	14	12
12	16		14	12	Not Recommended	

GROUNDING INSTRUCTIONS

1. All grounded, cord-connected tools:

In the event of a malfunction or breakdown, grounding provides a path of least resistance for electric current to reduce the risk of electric shock. This tool is equipped with an electric cord having an equipment-grounding conductor and a grounding plug. The plug must be plugged into a matching outlet that is properly installed and grounded in accordance with all local codes and ordinances.

Do not modify the plug provided – if it will not fit the outlet, have the proper outlet installed by a qualified electrician.

Improper connection of the equipment-grounding conductor can result in a risk of electric shock. The conductor with insulation having an outer surface that is green with or without yellow stripes is the equipment-grounding conductor. If repair or replacement of the electric cord or plug is necessary, do not connect the equipment-grounding conductor to a live terminal.

Check with a qualified electrician or service personnel if the grounding instructions are not completely understood, or if in doubt as to whether the tool is properly grounded.

Use only 3-wire extension cords that have 3-prong grounding plugs and 3 pole receptacles that accept the tool's plug.

Repair or replace damaged or worn cord immediately.

2. Grounded, cord-connected tools intended for use on a supply circuit having a nominal rating less than 150 volts:

This tool is intended for use on a circuit that has an outlet that looks like the one illustrated in Sketch A in Fig. 1. The tool has a grounding plug that looks like the plug illustrated in Sketch A in Fig. 1. A temporary adapter, which looks like the adapter illustrated in Sketch B and C, may be used to connect this plug to a 2-pole receptacle as shown in Sketch B if a properly grounded outlet is not available. The temporary adapter should be used only until a properly grounded outlet can be installed by a qualified electrician. **This adapter is not permitted in Canada.** The green-colored rigid ear, lug and the like, extending from the adapter, must be connected to a permanent ground such as a properly grounded outlet box.

3. Grounded, cord-connected tools intended for use on a supply circuit having a nominal rating of 150–250 volts, inclusive: This tool is intended for use on a circuit that has an outlet that looks like the one illustrated in Sketch D. The tool has a grounding plug that looks like the plug illustrated in Sketch D. Make sure the tool is connected to an outlet having the same configuration as the plug. No adapter is available or should be used with this tool. If the tool must be reconnected for use on a different type of electric circuit, qualified service personnel should make the reconnection; and after reconnection, the tool should comply with all local codes and ordinances.

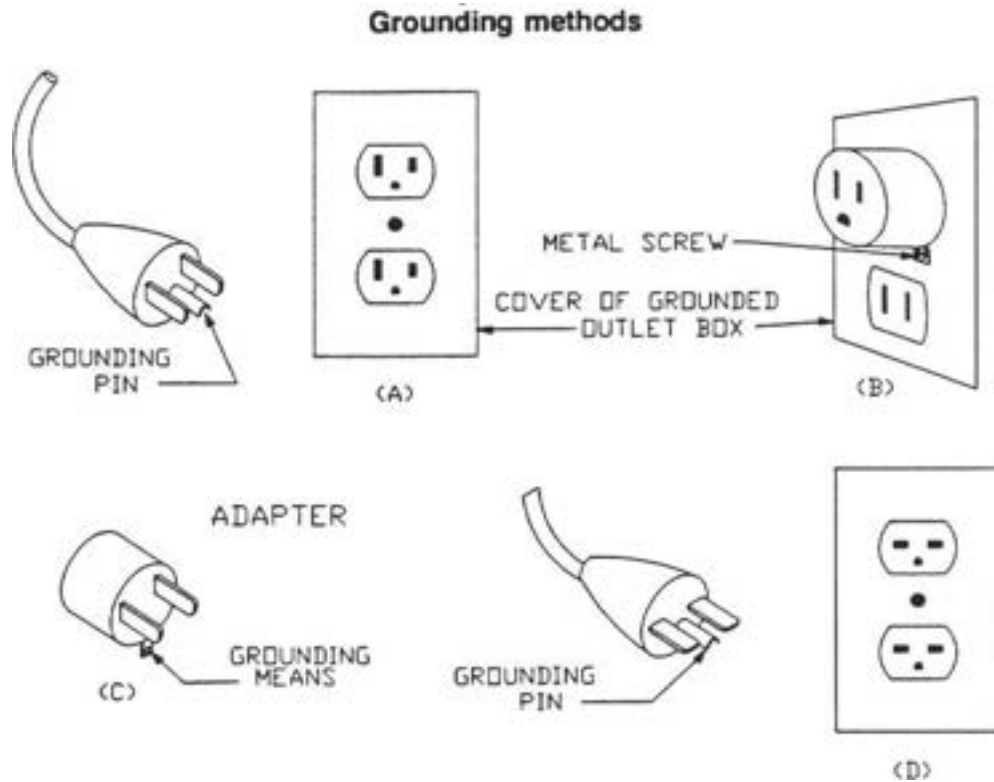

Fig. 1

TABLE OF CONTENTS

DEAR WOODWORKER	2
INTENDED USE	3
GROUNDING INSTRUCTIONS	6
LIMITED WARRANTY	9
DEFINITIONS	10
NOISE EMISSION	11
SPECIFICATION SHEET	11
INTRODUCTION TO YOUR MACHINE	12
PARTS OF THE BANDSAW	13
WHERE TO LOCATE YOUR MACHINE	18
PACKAGING CONTENTS	20
OPTIONAL ACCESSORIES (EACH SOLD SEPARATELY).....	21
QUICK START	22
ASSEMBLY AND SETUP	23
ASSEMBLING THE STAND AND CASTERS.....	24
BLADE TENSION KNOB.....	28
INSTALLING THE TABLE.....	29
INSTALL LEVELING BOLT.....	30
INSTALLING THE FENCE AND GUIDE RAIL.....	30
ADJUSTMENTS	31
CENTERING THE TABLE.....	31
TILTING THE TABLE.....	31
ADJUSTING THE FENCE FROM HIGH TO LOW POSITION.....	32
SQUARING THE BLADE TO THE TABLE.....	33
SQUARING THE FENCE TO THE TABLE.....	34
SQUARING THE REAR OF THE BLADE TO THE TABLE.....	35
TRACKING THE SAW BLADE.....	36
ADJUSTING THE BLADE TENSION.....	36
ADJUSTING THE BLADE GUIDES.....	37
ADJUSTING THE BLADE GUARD.....	39
CHANGING THE BLADE SPEED & ADJUSTING THE DRIVE BELT TENSION	40
CHANGING THE MOTOR DRIVE BELT	41
CHANGING BANDSAW TIRES	41
CHANGING THE BANDSAW BLADE	42
ADJUSTING FOR DRIFT	43
TEST RUN	44
USING THE BANDSAW	45
SELECTING A BLADE	46
HOW TO COIL A BANDSAW BLADE	47
MAINTENANCE AND TROUBLESHOOTING	50
ELECTRICAL DRAWING	58
EXPLODED VIEW DRAWINGS AND PARTS LIST	59

LIMITED WARRANTY

WARRANTY & REGISTRATION

Thank You!

Welcome to the Laguna Tools® group of discriminating industrial machinery owners. We understand that you have a choice of where to purchase your machines and appreciate the confidence you have in the Laguna Tools® brand.

Through hands-on experience, Laguna Tools® is constantly working hard to make innovative, precision products. Products that inspire you to create works of art are a joy to operate and encourage your best work.

Laguna Tools®
Imagination, Innovation, and Invention at Work

Warranty & Registration

Every product sold is warranted to be free of manufacturer's defective workmanship, parts, and materials. For any questions about this produce, the intended use or what it was designed for, customer service, or replacement parts, please contact our customer service department:

Laguna Tools® Customer Service
744 Refuge Way, Grand Prairie, Texas 75050, USA
1-800-234-1976
customerservice@lagunatools.com
www.lagunatools.com/why/customer-service/
8AM. To 5PM PSF. Monday through Friday

For warranty claims or to report damage upon receiving-please reach out to our warranty department:

Laguna Tools® Warranty Service
744 Refuge Way, Grand Prairie, Texas 75050, USA
1-800-234-1976
customerservice@lagunatools.com
www.lagunatools.com/policies/warranty
8AM to 5PM PST, Monday through Friday

Registration

To prevent voiding this warranty, all products sold must be registered within thirty (30) days of receiving the product. Registering the product will enable the original purchaser to receive notifications about important product changes, receive customer service, and be able to file a warranty claim against defective workmanship, parts, or materials.



Who is Covered

The applicable warranty covers only the initial purchaser of the product from the date of receiving the product. To file such claims, the original purchaser must present the original receipt as proof of purchase.

What is Covered

The warranty covers any defects in the workmanship of all parts and materials that make up the machine unless otherwise specified. Any part determined by Laguna Tools® to have a defect will be repaired or replaced (and shipped), without charge. The defective item/part must be returned to Laguna Tools® with the complaint and proof of purchase in the original packaging that it was received in. In the event the item/part is determined to be not covered by this warranty, the customer will be responsible for the cost to replace the item/part and all related shipping charges.

Warranty Limitations

This limited warranty does not apply to natural disasters, acts of terrorism, normal wear and tear, product failure due to lack of maintenance or cleaning, damage caused by accident, neglect, or lack-of inadequate dust collection. The warranty may be voided against proof of misuse/abuse, damage caused where repair or alterations have been made or attempted by others, using the product for purposes other than those described as intended use (unless with consent by Laguna Tools®), modification to the product, or use with an accessory that was not designed for the product. It is the responsibility of the user to understand basic woodworking machinery settings and procedures and to properly maintain the equipment in accordance with the standards provided in this manual.

Length of Warranty

All new machines and optional accessories sold through an authorized dealer carry a two-year warranty effective from the date of receiving the product. Machines sold for either commercial or industrial use have a one-year warranty. Wearable parts like throat plates, bandsaw guides, etc., have a ninety-day warranty.

Table A-1 Warranty Lengths

2 Year – New Machines Sold Through an Authorized Dealer

2 Year – Accessories Sold as Machine Options (excluding blades)

1 Year – Machines Sold for Commercial or Industrial Use

1 Year – Blades and Accessories outside of Machine Options

90 Days – Wearable Parts

Aside from being free of defects upon receiving, consumable parts, like cutters and abrasives, are not covered by this warranty unless otherwise stated by Laguna Tools®. These parts are designed to be used at the expense of the operator and are available for replacement or inventory purchase. The determination of a consumable part will be made on a case-by-case basis by Laguna Tools®.

Shipping Damage

Laguna Tools® is not responsible for damage or loss caused by a freight company or other circumstances not in the direct control of Laguna Tools®. All shipping-related claims for loss or damage to goods must be made to Laguna Tools® within twenty-four hours of delivery.

How to Receive Support

To file a warranty claim, please contact the warranty department at 1-800-234-1976. To receive customer service or technical support, please contact the customer service department at 1-800-332-4094. Parts, under warranty, are shipped at the expense of Laguna Tools® either by common carrier, FedEx ground services, or similar method. Technical support to install replacement parts is primarily provided by phone, fax, email, or the Laguna Tools® Customer Service Support Website.



© 01/2025 Laguna Tools, Inc.

DEFINITIONS

1. **Bandsaw Blade:** A continuous loop of toothed metal used for cutting materials.
2. **Tooth Pitch:** The distance between the tips of adjacent teeth on the blade.
3. **Tooth Set:** The bending of teeth to the right or left to allow clearance through the cut.
4. **Upper Wheel:** The wheel that helps moves the blade and where the blade rotates on.
5. **Lower Wheel:** The wheel that guides and tensions the blade.
6. **Blade Guides:** Components that keep the blade aligned during cutting.
7. **Thrust Bearing:** A bearing behind the blade that supports it under cutting pressure.
8. **Bandsaw Table:** The flat surface where material rests during cutting.
9. **Table Tilt:** The ability of the table to tilt for angled cuts.
10. **Blade Tension:** The tightness of the blade, affecting accuracy and blade life.
11. **Blade Tracking:** Adjusting the blade to stay centered on the wheels.
12. **Wheel Brush:** A brush that removes debris from the lower flywheel during operation.
13. **Resawing:** Cutting a board along its thickness to produce thinner pieces.
14. **Rip Cut:** Cutting along the grain of the wood.
15. **Crosscut:** Cutting across the grain of the wood.
16. **TPI (Teeth Per Inch):** The number of teeth per inch, affecting cut smoothness and speed.
17. **Gullet:** The curved area at the base of the tooth that carries away chips.
18. **Tooth Rake Angle:** The angle of the tooth face relative to the cutting direction.
19. **Vertical Bandsaw:** A bandsaw with a vertically moving blade; material is manually fed.
20. **Horizontal Bandsaw:** A bandsaw with a horizontally moving blade; often used for metal cutting.

NOISE EMISSION

Notes concerning noise emission

Given that there exists a relationship between noise level and exposure times, it is not precise enough to determine the need for supplementary precautions. The factors affecting the true level of exposure to operators are clearly the amount of time exposed, the characteristics of working environment, other sources of dust and noise, etc. For example, adjacent machines may contribute to the level of ambient noise. It is possible that exposure level limits will vary from country to country.

SPECIFICATION SHEET

Motor	120Volt AC/60HZ/1HP
Amperage	6 Amps
Table Size	13.8" x 12 1/2" (350mm x 318mm)
Table tilt	0 degrees - 45 degrees
Table height to floor	14 1/2" (368mm)
Fly wheel	Cast iron
Resaw Capacity	5.75" (147mm)
Blade length	70 1/2" (1,790mm)
Minimum blade width	1/8" (3mm)
Maximum blade width	1/2" (13mm)
Blade Included	3/8" (9.5mm)
Guides	Micro-adjustable roller bearing
Machine Dimensions without stand (L x W x H)	22.8" x 22" x 32.3" (580mm x 560mm x 821mm)
Machine Dimensions with optional adjustable stand (L x W x H)	28.3" x 25.6" x 55.1"–63" [adjustable] (720mm x 650mm x 1400–1600mm) [adjustable]
Weight gross	99.2 lbs (45kgs)
Weight net	95lbs (44kgs)
Package size	(35.5"x 15.75"x17.75") (900mm x 400mm x 455mm)
Mobility kit	Optional
Industrial work-light	Optional
Adjustable Height Stand	Optional
Roller Outfeed Table	Optional

RECEIVING YOUR MACHINE

Following delivery and before the driver has left, inspect the packing, invoice, and shipping documents. Next, ensure there is no visible damage to the packaging or the machine. All damage must be noted on the delivery documents and signed by the receiver and the delivery driver. Contact Laguna Tools Customer Service as soon as possible in case of damage. It is advisable to photograph and document any shipping damage. The original packaging is required to return damaged equipment to Laguna Tools.

INTRODUCTION TO YOUR MACHINE



*Shown with optional accessories

This bandsaw is designed for years of safe service. Read the owner's manual before assembly or use. A bandsaw has an endless steel blade with teeth on one side that rotates around two wheels, creating continuous sawing action. The blade's downward direction minimizes kickback, unlike circular saws. Woodworkers prefer bandsaws for safety, especially when cutting small pieces. Bandsaws can cut curves by rotating the workpiece around the blade and can cut thick stock with minimal horsepower, making them ideal for creating thin veneer from valuable wood.

PARTS OF THE BANDSAW



*Shown with optional accessories

- 1—Upper Door
- 2—Column Post Cap
- 3—Upper Wheel
- 4—Blade Tension Knob
- 5—Blade Tracking Window
- 6—Door Latch
- 7—Rip Fence Assembly
- 8—Blade Guide
- 9—Light ON/OFF Switch
- 10—Power ON/OFF Switch
- 11—Lower Door
- 12—Dust Collection Port
- 13—Blade Window
- 14—Lower Wheel

- 15—Stand (optional)
- 16—Quick Release Blade Tension Lever
- 17—Tracking Handle and Locking Knob
- 18—Blade Guard Adjustment Knob
- 19—Tool Holder
- 20—110V Power Socket
- 21—Blade
- 22—Table
- 23—Outfeed Roller Table (optional)
- 24—Lower Flywheel Shaft Adjusters
- 25—Dust Collection Port
- 26—Power Cord
- 27—Drive Belt Tension Release Nut
- 28—Motor

The bandsaw does not have many parts. The major parts are discussed in this manual. If you are not familiar with the bandsaw, take the time to read this section and become familiar with the machine

1. Upper door

Allows access to the to upper wheel.

2. Column Post Cap

Prevents debris from entering the machine.

3. Upper wheel

Wheel on the upper half of the machine that the bandsaw blade goes around.

4. Blade tension knob

Tightens and loosens the bandsaw tension. Clockwise-tightens. Counterclockwise-loosens.

5. Blade Tracking Window

Allows the operator to safely view the blade tracking of the bandsaw. The bandsaw blade should be adjusted so that the blade is centered on the upper wheel when the wheel is spinning. This is adjusted by turning the tracking knob on the rear of the upper cabinet to center the blade while turning the upper wheel by hand. Make sure to unplug the bandsaw prior to adjusting the tracking.

6. Door latch

Locks the door in place so that it does not open during operation.

7. Rip Fence Assembly

Guides the workpiece securely, ensuring straight and accurate cuts, especially during ripping and resawing, and helps compensate for blade drift. The rip fence assembly consists of a solid guide rail, cast-iron knuckle, fence attachment block, and a high-low fence. The guide rail is attached to the front edge of the table. It guides the fence assembly side to side across the table. The cast knuckle slides on the guide rail and is lockable in any position with a knob to suit the width of the cut. The fence attachment block is secured to the fence knuckle with 2 screws. These screws can be loosened to pivot the fence to adjust for blade drift. The fence can be fitted in the low 1/2" or high 5-1/2" position

8. Blade guide

There are two sets of blade guides, one above and one below the table. The function of the guides is to give the blade stability and ensure that the blade movement left/right, forward/back is kept to a minimum. The guides above the table are fitted to a shaft that has vertical adjustment. The upper guides are adjustable so that the guides are held just above the job being cut. This gives the blade the maximum amount of stability and also keeps the amount of blade that is exposed to a minimum. The guides have micro-adjustable bearings that can be adjusted for near zero clearance

9. Light ON/OFF Switch

Powers the built-in bandsaw light on and off.

10. Power ON/OFF Switch

Powers the bandsaw on and off. Upper button-ON Lower button-OFF

11. Lower Door

Allows access to the lower wheel

12. Dust Port

Port for dust collection hose to extract dust

13. Blade Window

Window that allows the operator to view the blade on the lower wheel.

14. Lower Wheel

Wheel on the lower half of the machine that the bandsaw blade goes around.

15. Adjustable Height Stand (sold separately)

Optional stand that elevates and stabilizes the bandsaw.

16. Quick Release Blade Tension Lever

Quickly releases blade tension. This tension lever is at the back of the bandsaw. This lever is a convenient way of quickly releasing the tension on the blade and speeds up the blade change dramatically.

17. Blade Tracking Knob

The blade-tracking knob is located at the back of the bandsaw and is used to adjust the blade tracking. The knob must be locked once the adjustment is completed.

18. Upper Guide Post Adjusting Knob and Lock

The upper blade guide is fixed to the blade guide shaft, which is vertically adjustable. Once the guides have been adjusted vertically, the shaft is locked in position with the lock knob.

19. Tool Holder

Holds tools that may be needed for maintenance

20. 120V Outlet

110V outlet that works when machine is connected to power.

21. Blade

Blade that cuts the material

22. Table

The table supports the work piece and can tilt to produce cuts at various angles. It has a miter slot to the right-hand side of the blade, which is used to guide the miter gauge. In the center there is a table insert which the blade passes through. Should the blade wander off center, this table insert will protect the blade from damage, as it is soft and should not damage the blade. The table also supports the adjustable fence, which is used for parallel cuts. There is a nut and bolt that join both sides of the table and stops the table from warping. The nut and bolt must always be fitted in the table and only removed when removing or fitting a blade.

23. Outfeed Roller Table (sold separately)

Optional roller table that helps with offloading cut material.

24. Flywheel Assembly with Shaft Nut

Secures the flywheel assembly.

25. Dust Port

Port for dust collection hose to extract dust

26. Power Cord

Cord that provides power to the machine

27. Drive Belt Tension Release Nut

Releases Tension from the belt.

28. Motor

The bandsaw is supplied with a 1 hp, 120V motor. It drives the lower flywheel through a drive belt.

Guards

When running, the blade can be very dangerous, and the amount of blade that is exposed must be kept to a minimum. The machine is supplied with a blade guard.

Tilt and tension mechanism

The upper wheel is attached to the tilt and tension mechanism. This mechanism adjusts the wheel so that the bandsaw blade can be adjusted for tracking. This is achieved by a screwed handle at the back of the machine that pushes on the mechanism and adjusts the axis of the wheel so that it runs true with the lower wheel.

The second function is to tension the blade, which is achieved by adjusting the upper flywheel vertically. A blade tension handle is located on top of the machine. The machine has a quick-acting blade release mechanism that is located at the back of the machine and will remove the tension from the blade to speed the removal and fitting of blades. The mechanism has a spring, which helps to keep the tension constant as the blade expands and contracts with the heat generated by the cutting action.

Electrical connection

The bandsaw is provided with a cable and 120V plug.

Identification

There is a plate at the back of the machine listing all the manufacturing data, including the serial number, model and blade length.



WHERE TO LOCATE YOUR MACHINE

Before you remove your bandsaw from the pallet, select the area where you will use your machine. There are no hard-and-fast rules for its location, but below are a few guidelines.

1. There should be an area at the front and back of the machine suitable for the length of wood that you will be cutting. If you intend to use your saw for scrollwork, this may not be important but should be considered at this stage
2. Locate machine in a dry environment.
3. Adequate lighting. The better the lighting, the more accurate and safely you will be able to work
4. Solid floor. You should select a solid, flat floor, preferably concrete or something similar.
5. Close to power source and dust collection.

UNPACKING YOUR MACHINE

To unpack your machine, you will need tin snips, knife and a wrench.

TWO PEOPLE ARE REQUIRED FOR UNPACKING AND SETUP & ASSEMBLY.

Note: The machine is heavy, and if you have any doubt about the described procedure, seek professional assistance. Do not attempt any procedure that you feel is unsafe or that you do not have the physical capability of achieving.

Using the tin snips, cut the banding that is securing the machine to the pallet (if fitted).

WARNING: EXTREME CAUTION MUST BE USED BECAUSE THE BANDING WILL SPRING AND COULD CAUSE INJURY.

Your bandsaw will be shipped in custom packaging consisting of a heavy-duty cardboard box and styrofoam internal packaging.

1. Select an area for the machine that has a strong, level foundation (workbench, stand, or floor) that is located in an area that has ample space (3ft minimum) on all sides of the machine for cutting large or long material.
2. Align the machine so that during use, the material being cut will not face aisles, doorways, or other work areas that bystanders may be in. Do not locate or use the machine in damp or wet conditions.
3. If desired, secure the machine with lag screws (not supplied) using the 4 holes in the machine's base.
4. For best power and safety, the bandsaw should be plugged directly into a dedicated grounded electrical outlet that is within the supplied cord length of the machine. The use of an extension cord is not recommended. See safety information section.
5. Open the cardboard box and remove any loose parts and styrofoam.
6. Tilt the packing on the side and slide the bandsaw out of the packaging. You will need two or more people, as the bandsaw is heavy.
7. Lift the bottom styrofoam out and remove the parts that may be packaged under the bandsaw and packaging.

PACKAGING CONTENTS

- A. Bandsaw Frame Assembly
- B. Table with Blade Insert
- C. Front Rail for Rip Fence
- D. Rip Fence with with Carrier Assembly
- E. Magnetic Dust Chamber
- F. Blade Tension Knob
- G. Leveling Bolt & Knob
- H. Bolts (4) and Lock Washers (4) to attach table to trunnion on bandsaw frame.
- I. Hex Wrenches; 3.5, 5, 6, 7 mm
- J. Wrenches: 10 mm and 13mm
- K. Owner's Manual (not shown)
- L. Stabilization Kit (knob, spring, small & large washer)

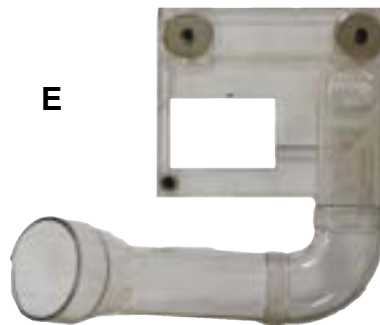

Optional Accessories (EACH SOLD SEPARATELY)

- A. Adjustable Stand [part no. 110001]
- B. Roller Outfeed Table [part no. 110004]
- C. Wheel Kit (4x casters) [part no. 110002]
- D. 3 Blade Pack [part no. 110003]
 - i. 1/4" x 6 TPI Blade
 - ii. 3/8" x 6 TPI Blade
 - iii. 1/2" x 6 TPI Blade
- E. Spinelock LED Lamp (not shown) [part no. ALEDSPINE]
- F. Magnetic Base for Spinelock Lamp (not shown) [part no. ALED-STRONGMAG]

A



B



C



D



QUICK START

This quick start is not an instructional guide. For specific operations, read the entire manual, seek training from experienced operators, and consult additional resources like "how-to" books, trade magazines, or websites.

To cut a long work piece, use a roll stand to support it.

IF USING A NEW BLADE, SLOWLY MAKE FIRST TWO OR THREE CUTS WITH SLIGHT PRESSURE, DOUBLING THE USUAL CUTTING TIME. THIS WILL BREAK IN THE NEW BLADE. THIS WILL ENSURE THE BLADE'S QUALITY AND LIFESPAN.

An operator completes the typical assembly and cutting operation(s) listed below:



CAUTION! Never leave the bandsaw running unattended. If not in use, unplug it from power and release the blade tension.

1. Assemble the bandsaw and optional accessories correctly.
2. Wear safety gear: Safety glasses, hearing protection, and no loose clothing.
3. Ensure the workpiece is suitable for cutting.
4. Check the blade guard: Ensure it's adjusted just above the workpiece (1/4" gap)
5. Inspect the blade: Look for cracks, dullness, or improper tension.
6. Adjust blade tension: Use the tension knob or lever to match the blade width.
7. Set blade tracking: Turn the upper wheel by hand and adjust tracking so the blade stays centered.
8. Adjust upper/lower guides and thrust bearings: Position them close to the blade without touching it. (1/16" gap)
9. Adjust fence and guide rail. Ensure the blade and fence are square to the table
10. Ensure the desired speed setting is set.
11. Ensure the bandsaw is on a stable surface and plugged into a 120V grounded outlet.
12. Plug in to a 120V power source and power on: Inspect the bandsaw and blade to ensure proper setup and adjustment.
13. Mark your cut line: Use a pencil or marker.
14. Adjust the fence or miter gauge for straight or angled cuts.
15. Turn on the saw: Let it reach full speed before cutting.
16. Feed the material slowly: Use both hands, keeping fingers away from the blade. Follow the line: Let the blade do the work—don't force it. Use a push stick if necessary.
 - a. TIPS: Use the right blade for the material. Make relief cuts for tight curves. Keep the workpiece flat on the table at all times.
17. After cutting, turn off machine and unplug: Wait for the blade to stop completely.
18. Clean the table: Remove sawdust and debris.
19. Loosen blade tension: If storing for a while, to extend blade life.

ASSEMBLY & SETUP



WARNING Do not install the machine in explosive environments!

- Choose an installation area with at least 3 feet of clearance around the machine, based on the size of the parts to be machined.
- Ensure the floor is level and strong enough to support the machine evenly on all four supports.
- The site must have a nearby power outlet, chip extraction connection, and adequate lighting.
- Some components may be removed for shipping; reinstall them as instructed.



WARNING

DO NOT PLUG THE MACHINE IN UNTIL SETUP AND ASSEMBLY IS COMPLETE!



WARNING

MACHINE IS HEAVY! TWO PEOPLE ARE REQUIRED FOR ASSEMBLY!



WARNING

At the end of assembly, ensure that all bolts and nuts tightened; otherwise, this may cause machine wobble or serious injury to the operator or other persons.

1. When locating a designated area for the machine, select an area for the machine that a strong, level foundation (workbench, stand, or floor) that is located in an area that has ample space (3ft minimum) on all sides of the machine for cutting large or long material.
2. Align the machine so that during use, the material being cut will not face aisles, doorways, or other work areas that bystanders may be in. Do not locate or use the machine in damp or wet conditions.
3. Once in place in your shop, level the machine with spacers so that it does not move during use. If possible, secure it with lag screws (not supplied) using the 4 holes in the machine's base.
4. For best power and safety, the bandsaw should be plugged directly into a dedicated grounded electrical outlet that is within the supplied cord length of the machine. The use of an extension cord is not recommended. See safety information section.

ASSEMBLING THE STAND AND CASTERS

This bandsaw can be purchased with an optional adjustable stand and casters (each sold separately). If a stand was not purchased, skip this section. Hand tighten all bolts and nuts until the end of assembly.

1. Open the box and remove all components and hardware from the box.
2. Attach the feet to the bottom of the extension legs.
 - a. Secure the jam nut on the threads.
 - b. Do this to all legs.



Fig. 2

2. Attach the extension leg to the main leg and secure with four bolts and nuts. Tighten with a 13mm wrench. Make sure the threads are pointed inside the leg.
 - a. Do this to all legs.



Fig. 3

3. Attach the upper brace to the outside of two legs with four bolts and nuts.
 - a. **HAND TIGHTEN THESE NUTS. THIS WILL ALLOW THE LEGS TO ADJUST.**



Fig. 4

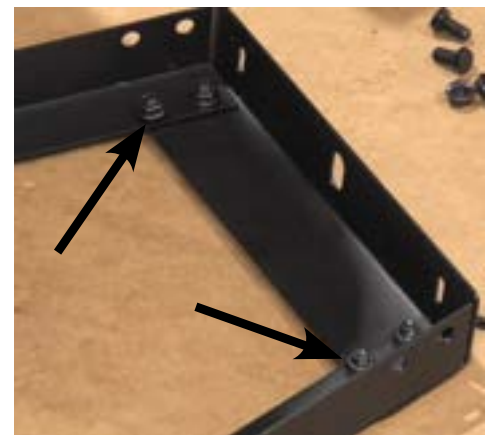

Fig. 5

4. Attach the short spanner brace to the middle of the legs with two bolts and nuts.

a. Do this to the other legs too.

HAND TIGHTEN THESE NUTS. THIS WILL ALLOW THE LEGS TO ADJUST.



Fig. 6

5. Slide the upper cross bars under the upper brace and above the leg. Attach the upper cross bars to the legs with two bolts and nuts.

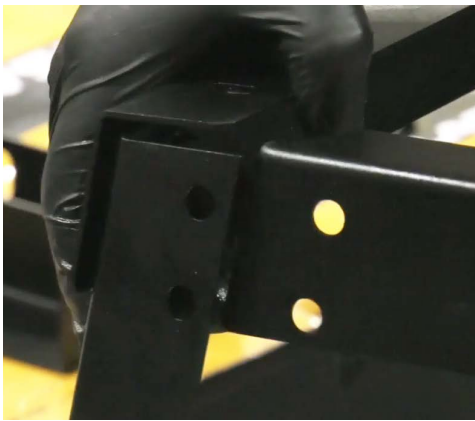

Fig. 7



Fig. 8

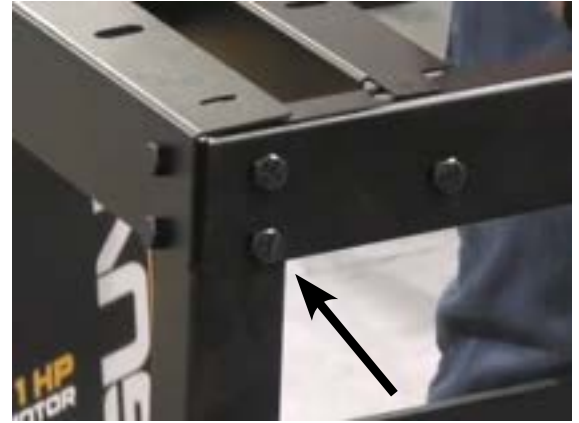

Fig. 9

7. Attach the cross bars to the other side using the same method and secure with the bolts and nuts. The stand should be similar to the figure below after this step.



Fig. 10

8. Attach the long spanners to the inside of the legs with the bolts and nuts.



Fig. 11

9. Slide the center supports in place and secure with the bolts and nuts on the front and rear of the supports. (Attaching the center supports is recommended but not required)



Fig. 12



Fig. 13

10. Make sure that all components and hardware are installed. (there may be some extra hardware)

11. Use a 13mm wrench and socket and tighten all bolt, nuts, and other fasteners.

For easier installation, it is recommended to place a piece of material under the leg to lift the stand off the ground

12. Remove the bolts from the casters

13. Position the caster inside the leg, aligning it with the second and third bottom holes.



Fig. 14

14. Secure with the bolts and tighten with a 13mm wrench or socket.

15. Repeat these steps for all casters.



Fig. 15



Fig. 16

16. After all casters are installed, adjust the leveling feet parallel with the wheel when the wheel lock is engaged (lever up) (Fig. 17)

The stand should roll freely without the rubber feet touching the ground when the wheel lock is disengaged (lever down).

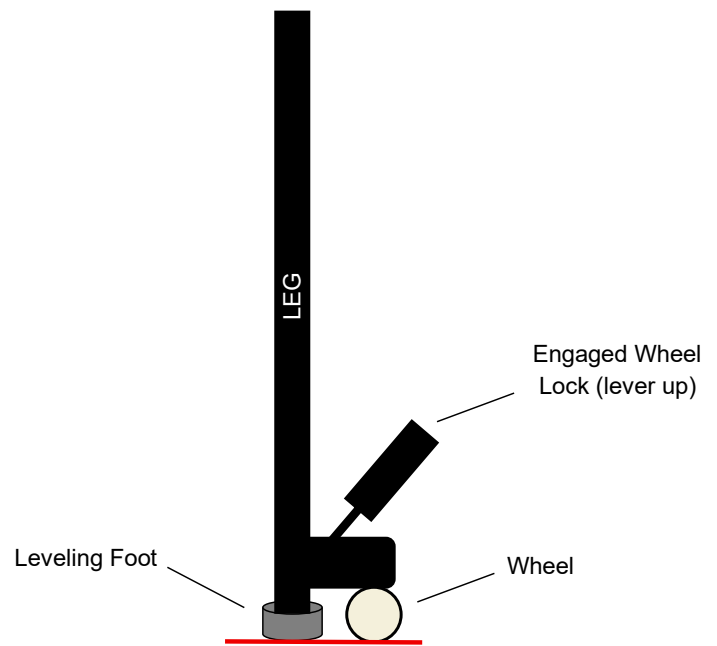

Fig. 17

Make sure that all fasteners are tight and the wheel lock is engaged (lever up) so the stand does not move.

TWO PEOPLE ARE REQUIRED TO MOVE THE BANDSAW. THE BANDSAW IS HEAVY! THE BANDSAW WEIGHS 95 POUNDS. USE PROPER LIFTING TECHNIQUE TO AVOID INJURY!

1. Open the box and remove all components and hardware from the box.
2. Take the band saw out of the box. It is recommended to turn the box vertically so that you can slide the band saw out.
3. Remove any coverings and other components.
4. With the help of another person, lift the bandsaw onto the stand, aligning the four corner holes with the stand hole(s).
5. Locate the four bolts that have two washers and two nuts on each of them.
6. Place a washer on top of the bandsaw corner hole and slide the bolt through. (Fig. 18)
7. From the underside, place a washer and the two nuts on the bottom of the bolt. (Fig. 19)
8. Use a 10mm wrench and socket to tighten. Ensure that the bottom nut is held so that the top bolt does not rotate freely.



Fig. 18 (top view)



Fig. 19 (bottom view)

BLADE TENSION KNOB

Place the blade tension knob onto the slot on the top of the machine.

Turn clockwise to tighten the blade tension and counterclockwise to loosen the blade tension.

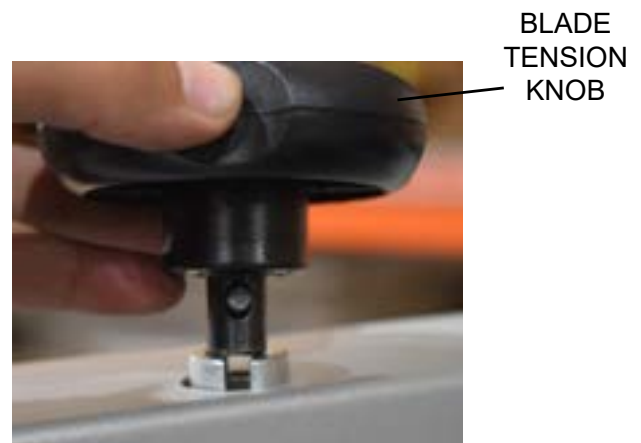
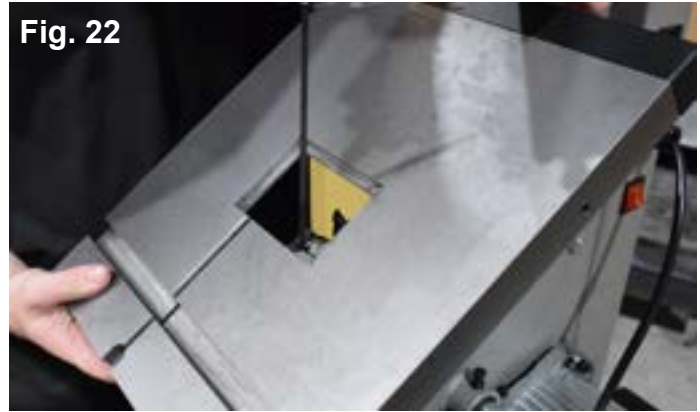

Fig. 20

INSTALLING THE TABLE

The table is shipped with protective grease on the surface. Wipe the table down with a rag and mineral spirits or WD-40 to clean off the protective grease.

1. Remove the red throat plate.
2. Fit the table onto the trunnion, with the slotted end pointing away from the machine. It is recommended that second person hold the table while the other person secures it.



2. Align the mounting holes on the trunnion.
3. Secure with four bolts and four teeth washers.(Fig. 23)
4. Use a 10mm wrench or socket to tighten.

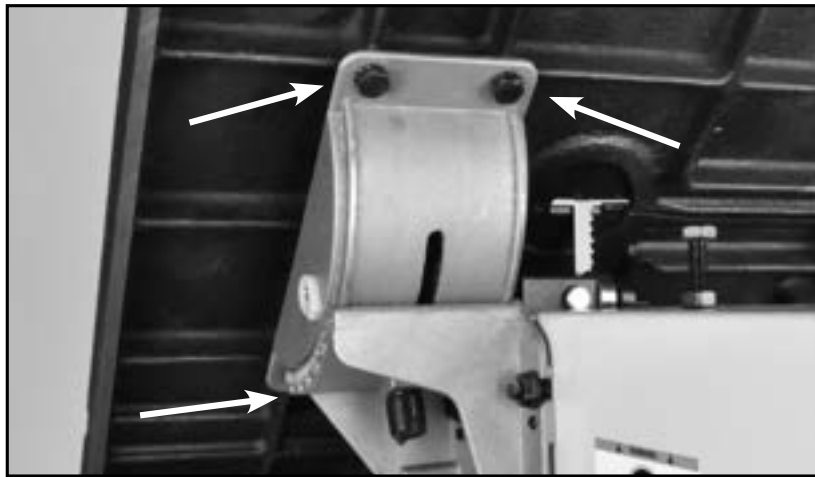

Fig. 23

2. Place the throat plate back in place with the slot towards the front of the saw.
 - a. Use an 3.5mm Allen key on the corner set screws to make any desired leveling adjustments.

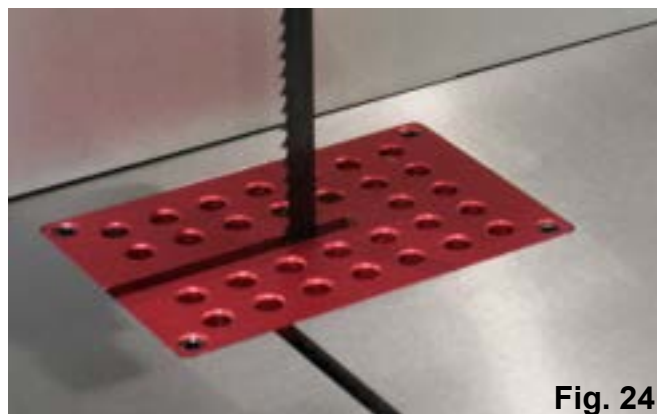

Fig. 24

INSTALL LEVELING BOLT

The leveling bolt helps keep the two sides of the table level at the slot area.

1. Insert leveling bolt through the front hole in the table and place the washer on the top side.
2. Turn the handle clockwise to tighten.

NOTE: The leveling bolt should be kept in place at all times, and only removed when the saw blade is changed.



Fig. 25

INSTALLING THE FENCE AND GUIDE RAIL

The fence acts as a guide so that the operator can make straight, accurate cuts. The guide rail allows for smooth movement and clamping of the fence.

1. Remove one nut from each of the threads on the guide rail.
2. Screw the remaining nuts on the guide rail all the way against the shoulder of the stud.
3. Slide the fence on the guide rail, positioning it on the inside of the blade. The fence tension knob may need to be loosened.

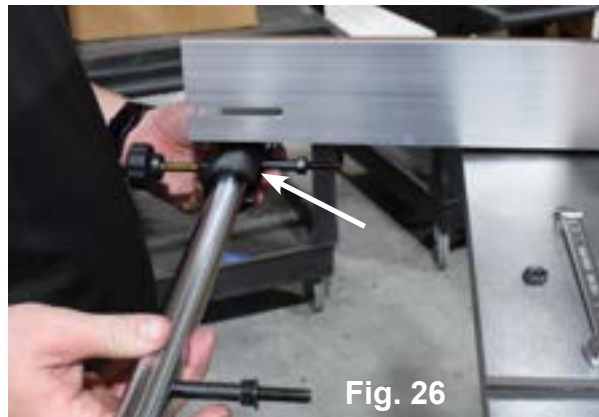

Fig. 26

4. Position the guide rail on the front edge of the table slide it to the inside of the blade and thread the nuts on the other side.
5. Tighten the nuts with a 10mm wrench.



Fig. 27



Fig. 28



Fig. 29

ADJUSTMENTS

CENTERING THE TABLE

If the bandsaw blade is not centered in the table during the initial table-to-trunnion assembly, additional table positioning adjustments may be needed.

1. Loosen the four trunnion nuts that hold the lower trunnion and table to the bandsaw frame.
2. Move the table sideways as required, until the saw blade runs through the center of the table insert.
3. Tighten the trunnion nuts that were adjusted.

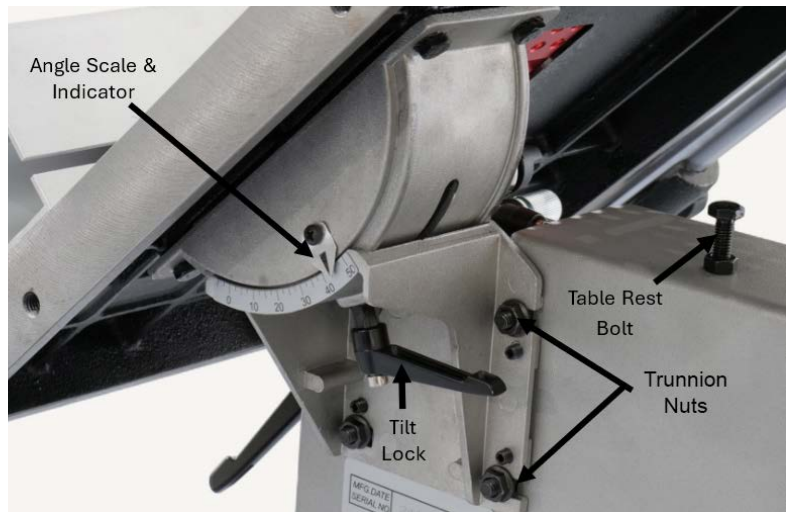

Fig. 30

TILTING THE TABLE

The table tilts from 0 to 45 degrees, allowing the operator to cut at different angles. **USE CAUTION WHEN CUTTING AT AN ANGLE!**

1. Loosen the tilt lock on the table trunnion.
2. Set the table to the desired angle and tighten the tilt lock.

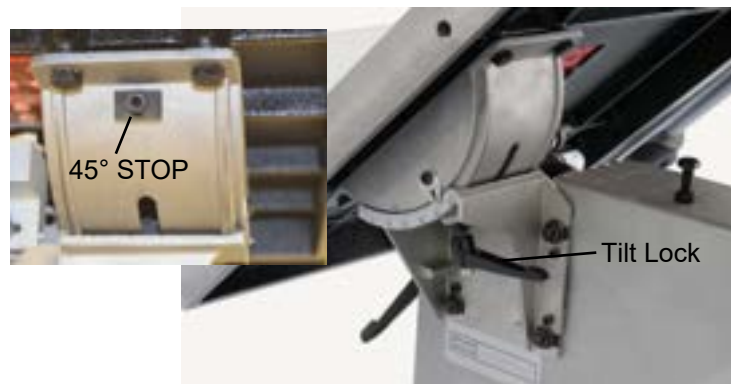

Fig. 31

The trunnion has a Stop for precise 45° angles. For critical cuts, verify the angle with an angle guide or trial cuts in scrap wood.

If cutting at a 0° angle, use the stabilization kit. (Fig. 31.1)

USE THE FENCE ON LOWER SIDE OF THE TABLE IF CUTTING AT AN ANGLE.

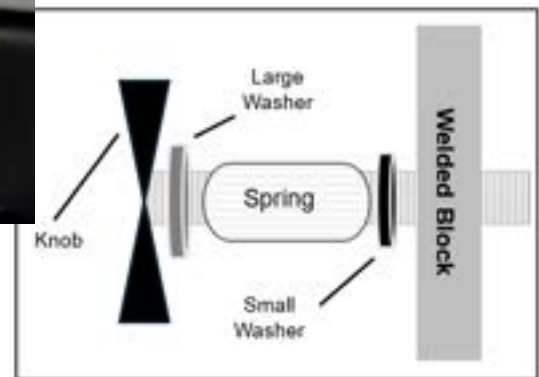

Fig. 31.1

ADJUSTING THE POSITION OF THE RIP FENCE

1. To adjust the position of the rip fence, loosen the fence knob counterclockwise.
2. Move the fence to the desired position.
3. Tighten the fence knob clockwise

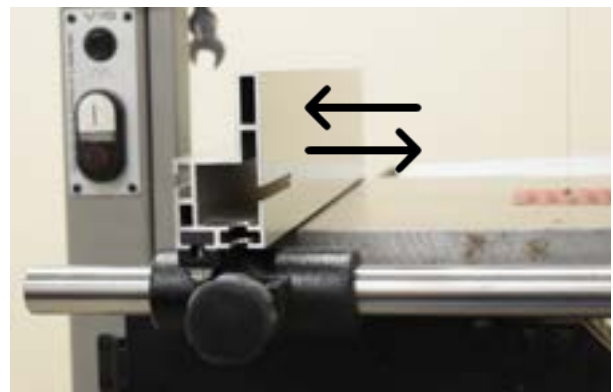

Fig. 32

ADJUSTING THE FENCE FROM HIGH TO LOW POSITION



WARNING! THE MACHINE MUST NOT BE PLUGGED IN AND THE POWER SWITCH MUST BE IN THE OFF POSITION UNTIL ALL ADJUSTMENTS ARE COMPLETE.

To change the fence from high to low position

1. Loosen the two hex screws with a 4mm Allen key.



Fig. 33

2. Slide the fence off of the plate, removing it from the carrier knuckle. (Fig. 34 & 35)



Fig. 34



Fig. 35

3. Rotate the fence right 90°, turning it to the low position, and slide it all the way back into the plate.

4. Line up the two holes and re-tighten the two hex screws with the Allen key to secure the fence.



Fig. 36



Fig. 37

5. Ensure the fence is parallel with the blade and miter gauge slot, adjusting for 'drift' if needed.

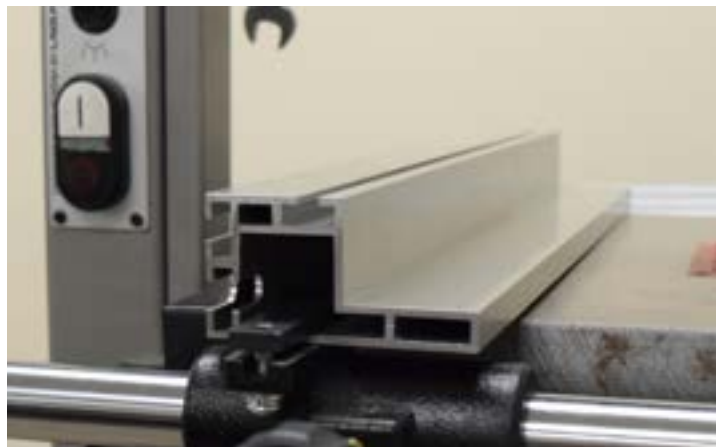

Fig. 38

SQUARING THE BLADE TO THE TABLE

1. Make sure that the table is set at 0° and not tilted left or right.
2. Place a square to the blade and check if the blade is 90° to the table. If there is a gap between the blade and the square as shown in Fig 39, follow the steps below.
3. Loosen the 90° table rest bolt's locking Nut and screw the bolt downward, away from the table underside.
Center the table until it the square is 90° to the blade.

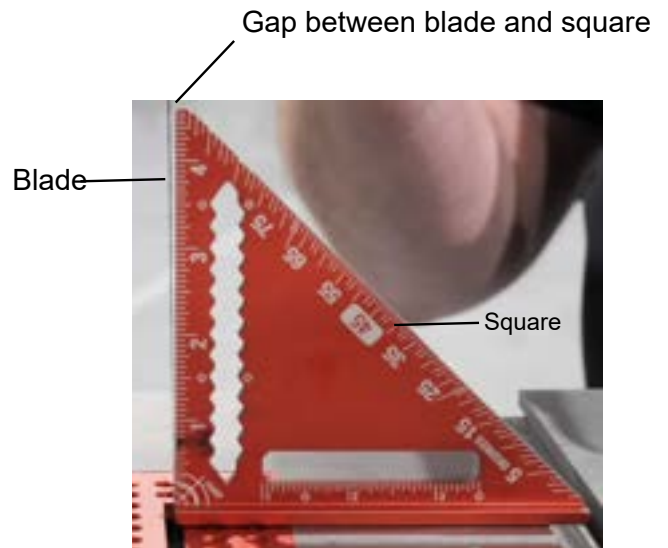

Fig. 39

4. Tighten the four flange nuts that were loosened in the "centering the table" section.
5. Check that the Table Angle Indicator reads zero degrees on the lower trunnion scale.
6. Loosen the screw holding the indicator and reset it to zero if necessary.

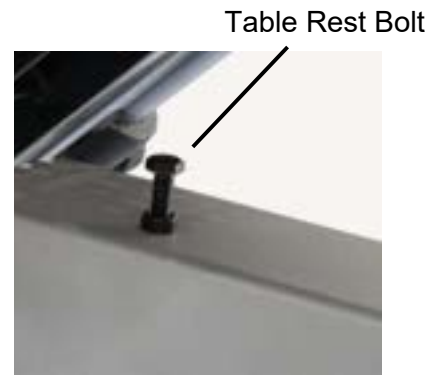

Fig. 40

7. With the table secured at 90°, adjust the table rest bolt up or down until it contacts the table underside.
8. Retighten the table rest locking nut, ensuring the 90° table angle setting is maintained (FIG. 41).

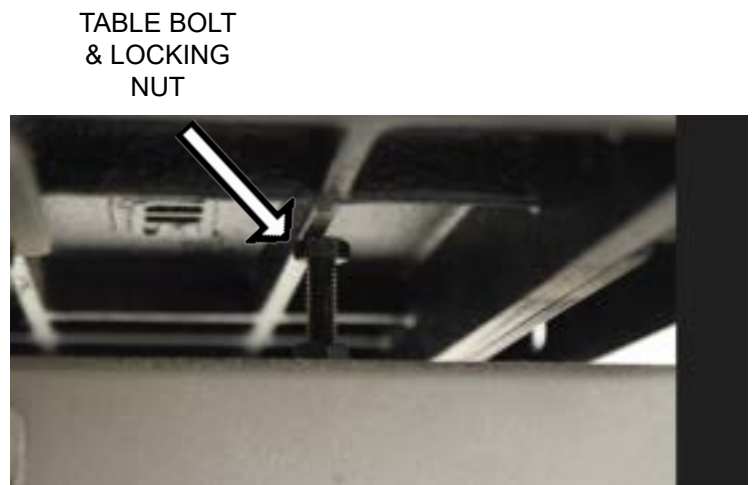

Fig. 41

SQUARING THE FENCE TO THE TABLE

1. Make sure that the table is set at 0° and not tilted left or right.
2. Place a square to the fence and check if the fence is 90° to the table. If there is a gap between the blade and the square as shown in Figure 43, follow the steps below.

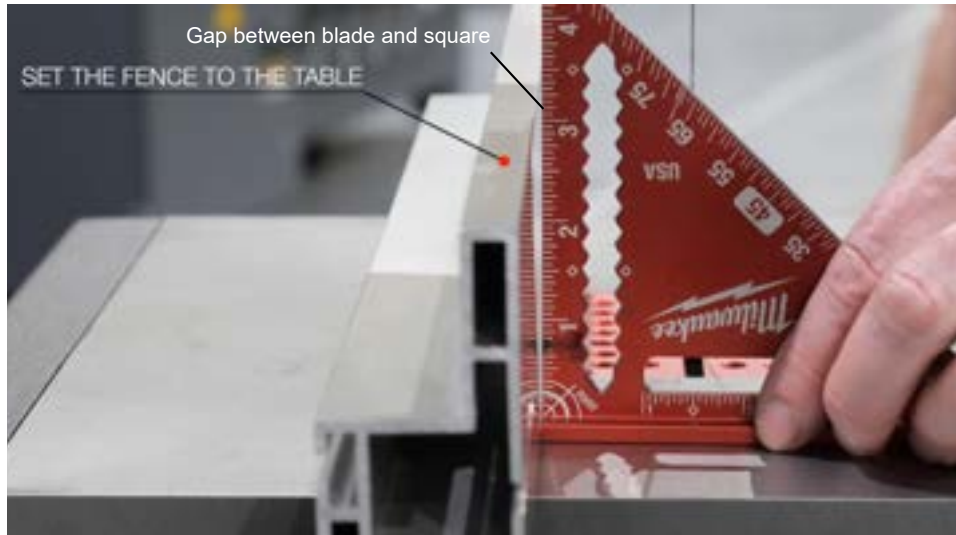

Fig. 43

3. Under the table, loosen one fence guide rail nut. Only loosen one nut at a time.
4. Raise/lower the fence until square and tighten nut.



Fig. 44

5. If the fence is still not square, loosen the other nut and repeat step 4.
6. Center the fence until it is 90° to the table.

SQUARING THE REAR OF THE BLADE TO THE TABLE



WARNING! UNPLUG THE MACHINE FROM POWER AND TURN OFF MACHINE. DO NOT POWER ON UNTIL ALL ADJUSTMENTS ARE COMPLETE.

If needed, the table can be reset to 90° to the back of the saw blade by adjusting the trunnion adjustment screws:

1. Loosen the four trunnion nuts on the lower trunion
2. Set a square on the table against the saw blade's back.
3. To adjust the table, use a 3mm Allen key to adjust the screws.
 - a. Adjust the screws in pairs; top two screws are a pair, bottom two screws are a pair. This will ensure proper adjustment. Do not mix and match the pairs.

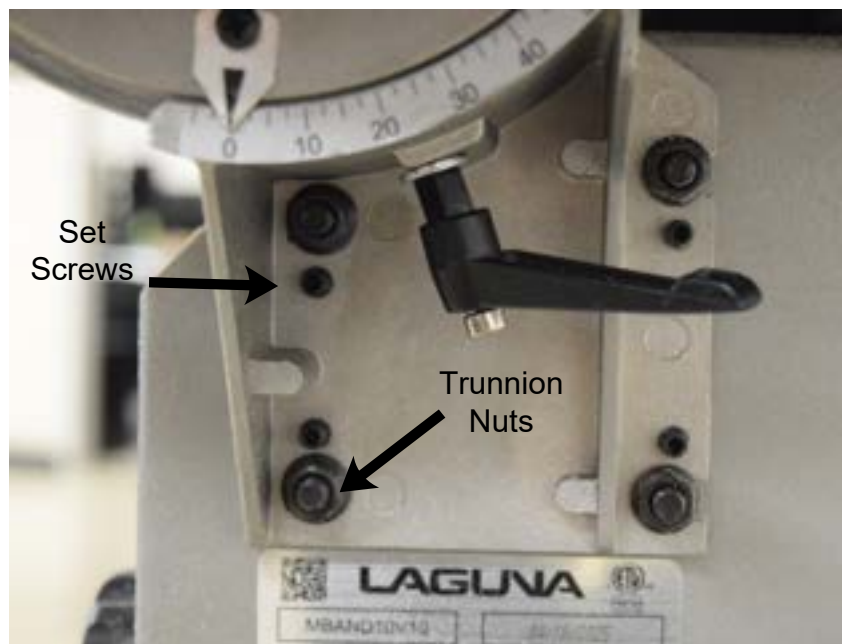

Fig. 45

Turning the set screws clockwise moves the support *away* from the saw. Turning the set screws counterclockwise moves the support *towards* saw.

4. Check the table and blade angle for 90°.

5. Tighten the trunnion nuts when set at 90°.

The blade should be centered in the throat plate.

ADJUSTING THE BLADE TENSION

⚠ CAUTION! Always tension the blade with the rear Quick Release Lever in the “ON” position. Failure to do so could result in lack of blade tension or tension failure. FIG. 50

NOTE: Release / turn ‘OFF’ the Tension Lever only to change the blade, or to prolong the life of the blade when the saw is not in use for extended periods.

1. Adjust the blade tension by turning the Blade Tension Knob on top of the saw (FIG. 50)
2. Turn the knob clockwise to tighten the blade tension and counterclockwise to reduce it.

NOTE: With the saw unplugged, the blade guard up, and the blade guides moved away, the blade should deflect about 1/4” when pressed to the side with a finger.

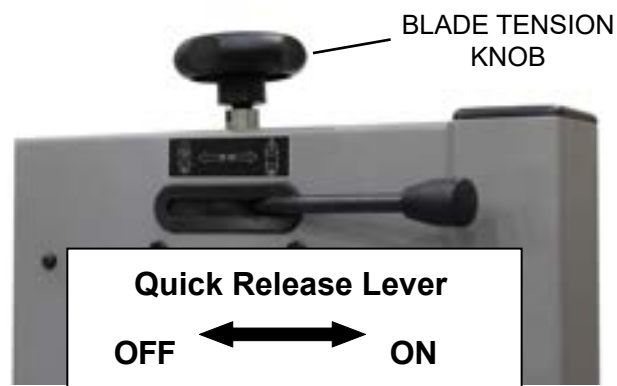
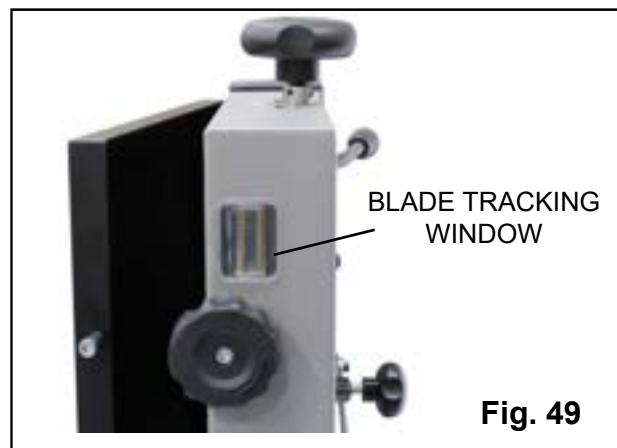

TRACKING THE SAW BLADE

⚠ WARNING! UNPLUG THE BANDSAW. A blade is installed at the factory. It is recommended to check the blade tracking prior to use. Make sure the upper and lower blade guides are adjusted away from the blade.

1. Open both upper and lower doors.
2. Loosen wing nut handle by turning it counterclockwise.

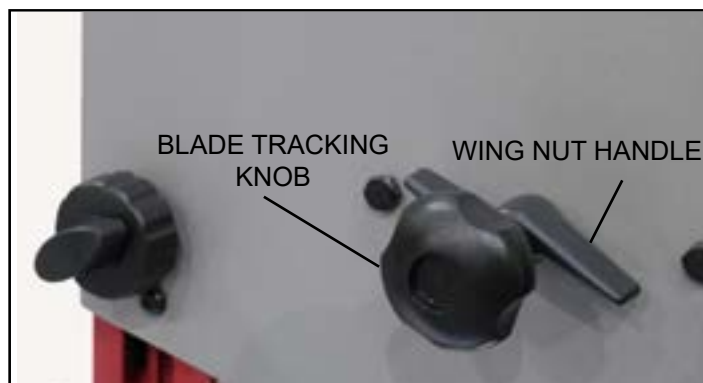

3. Turn the blade tracking knob while carefully rotating the upper wheel by hand.
 - Turn the knob clockwise to move the blade away from the door;
 - Turn the knob counterclockwise to move the blade towards the door.

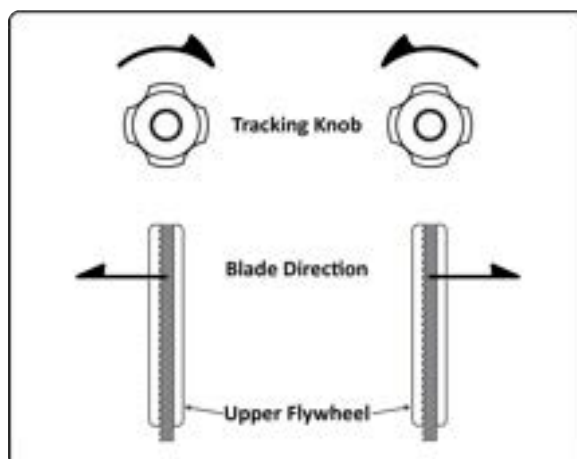

4. Check the blade tracking through the side window. Rotate the wheel at least three times or until the blade is centered (FIG. 47 & 48)



5. Once the blade is centered, tighten the wing nut handle and close the doors.

NOTE: 1/8" (3.18mm) blades should be 0.018" to 0.020" gauge to reduce tracking issues common with this width.

NOTE: The lower wheel has been pre-set at the factory and any changes made to this wheel should be done after reading this entire manual and understanding the instructions. Failure to do so could damage the machine.

ADJUSTING THE BLADE GUIDES

This bandsaw has quick-adjusting ball bearing blade guides for fast and easy setting to the blades. With the bandsaw blade properly centered on the drive wheels, the guide bearings can then be set. To adjust the blade guides:

Upper Guides:

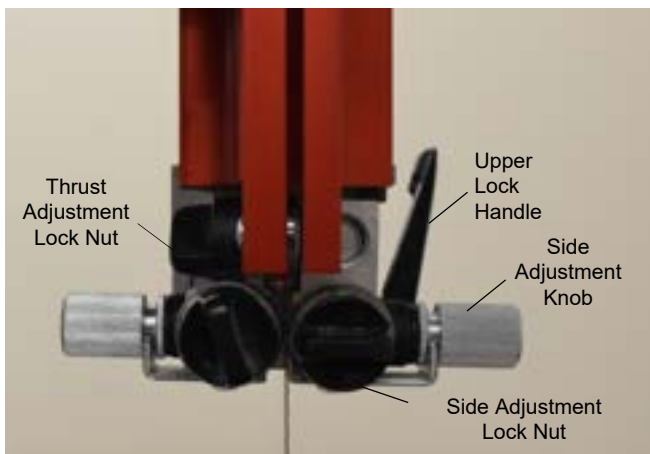

Fig. 51: Upper Guides (front view)

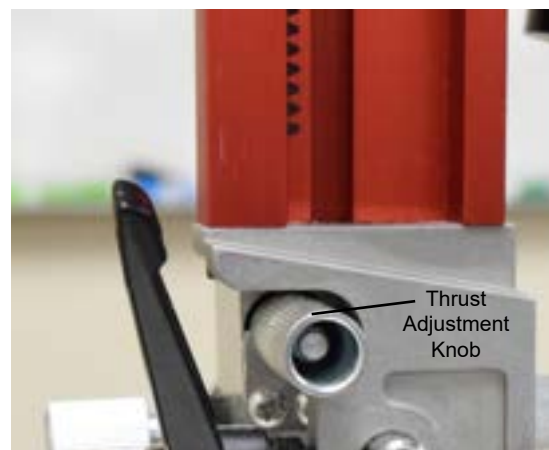

Fig. 52: Upper Guides (rear view)

1. Ensure the upper guide post is locked so that the guide post doesn't move during adjustment
2. Loosen the locking handle.
3. Move the guide assembly forwards/backwards to where side bearing is sitting just behind the blade teeth (about 1/16")
4. Tighten locking handle when done.

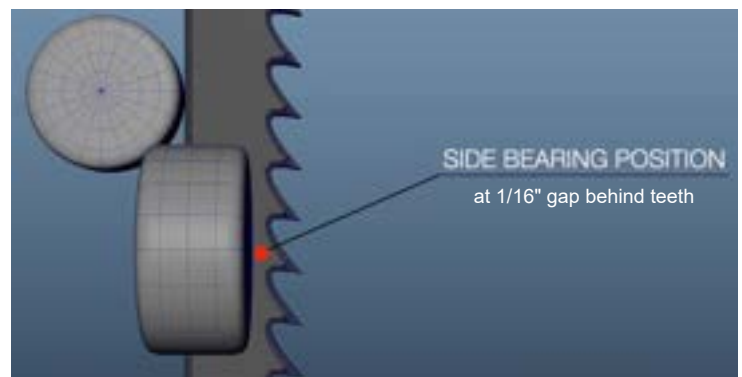

Fig. 53

4. Loosen the thrust adjustment lock nut
5. Adjust the thrust adjustment knob to where the thrust bearing is 1/32" gap away from the blade.
(clockwise=towards blade;
counterclockwise=away from blade)
6. Tighten the thrust adjustment lock nut to lock position.

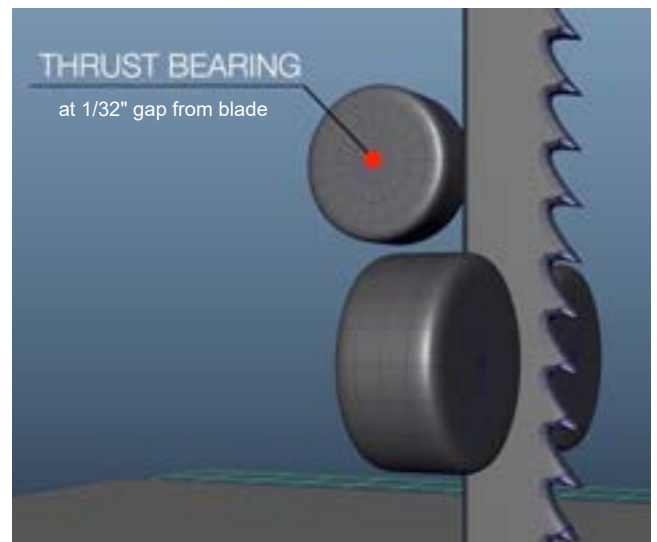

Fig. 54

7. Loosen both side adjustment lock nuts.
8. Adjust the side adjustment knobs to where both bearings are 1/32" (about the thickness of a piece of paper) gap away from the blade.
(clockwise=towards blade;
counterclockwise=away from blade)

The bearings should not continuously rotate when operating the bandsaw.

Lower Guides:

1. Loosen the lower lock handle.
2. Move the guide assembly forwards/backwards to where side bearing is sitting just behind the blade teeth (about 1/16")

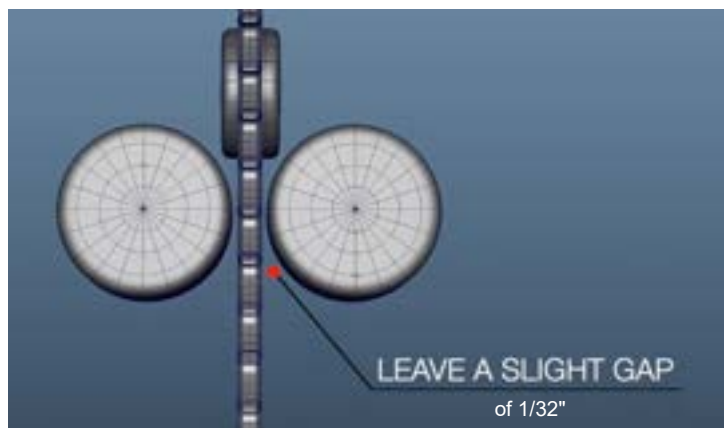

Fig. 55

3. Lock the handle.
4. Loosen the lower thrust adjustment lock nut.
5. Adjust the lower thrust adjustment knob to where the thrust bearing is 1/32" gap away from the blade.
(clockwise=towards blade;
counterclockwise=away from blade)
6. Tighten the thrust adjustment lock nut to lock position.
7. Loosen both lower side adjustment lock nuts.
8. Move the guides with your hand to where both bearings are 1/32" (about the thickness of a piece of paper) gap away from the blade.
(clockwise=towards blade;
counterclockwise=away from blade)

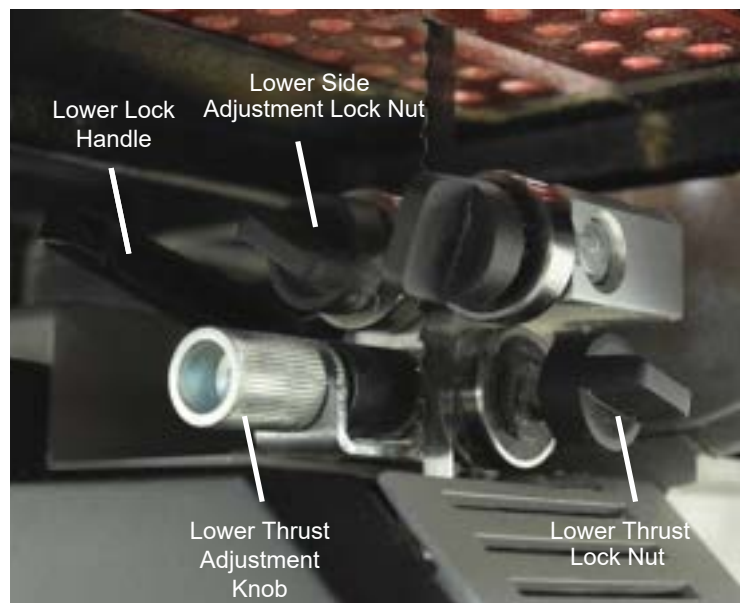

Fig. 56

9. Tighten both lower side adjustment lock nuts to lock position.

ADJUSTING THE BLADE GUARD

NOTE: Before cutting, set the upper guide approximately 1/4" above the top surface of the work piece. This will give the best blade control.

1. Loosen the guide lock knob.



Fig. 57

2. Rotate the guide adjustment knob to raise or lower the guide assembly to the desired height above the table or workpiece.

A 1/4" gap between the guide assembly and workpiece is recommended.

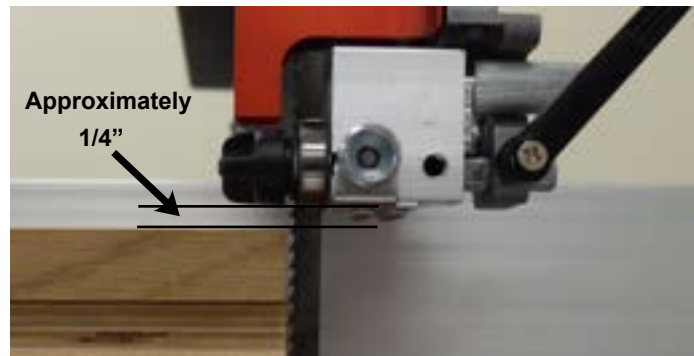

Fig. 58

3. When the guide bearings are properly positioned, tighten the guide lock knob loosened in step one.

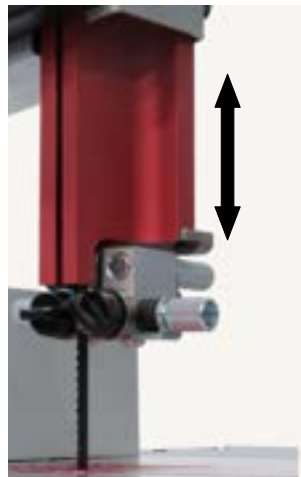

Fig. 59

CHANGING THE BLADE SPEED & ADJUSTING THE DRIVE BELT TENSION

This Bandsaw has two blade speeds, high speed (3,280 ft/min) and low speed (1,515 ft/min). Reference (Fig. 60). This figure is also found on the inside of the lower door.

NOTE: The bandsaw is shipped in the high speed mode.

The lower drive wheel has two pulleys, and the motor shaft has a two pulleys. The belt runs around both pulleys.

For HIGH SPEED (3,280 ft/min), install the belt on the rear pulleys of both the motor and wheel (positions 1 to 2). This setting is ideal for general sawing of wood and composites. The bandsaw is shipped in high speed mode.

For LOW SPEED (1,515 ft/min), install the belt on the front pulleys of both the motor and wheel (positions 3 to 4). This setting is best for cutting hard materials like thicker wood, Use the correct blade type for effective cutting.

Changing blade speeds and adjusting belt tension is done by pivoting the rear motor.

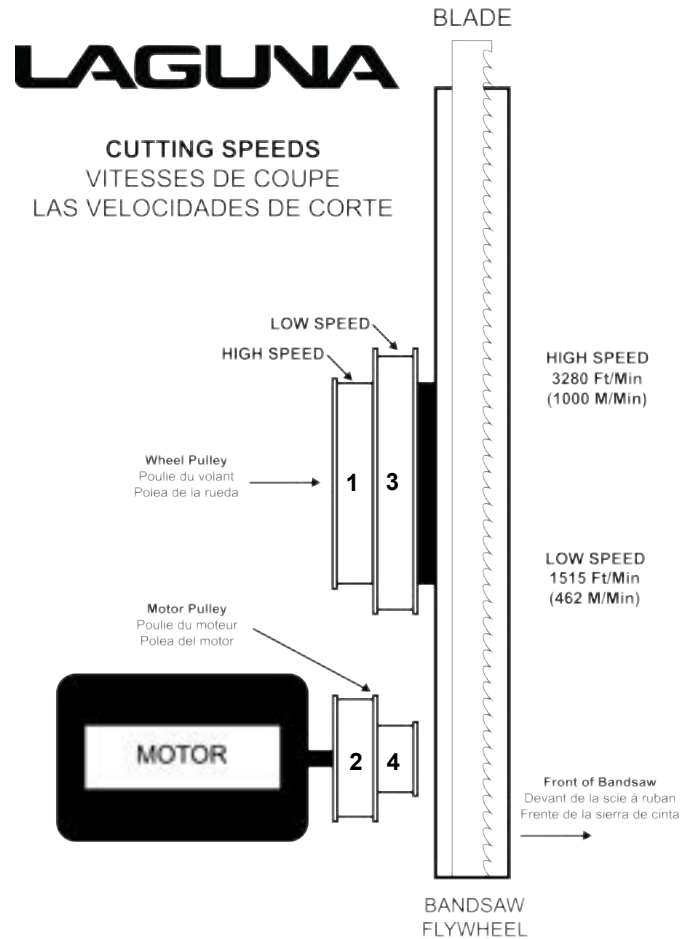

Fig. 60

To Change Blade Speeds:

1. Loosen the top motor mount screw and pivot the motor to release tension on the drive belt (FIG. 61)
2. Change the belt position to the desired blade speed.
3. Tension the drive belt to allow 3/8" to 1/4" deflection. Avoid over-tensioning to prevent damage to the belt, pulleys, and motor (FIG 62).
4. Tighten the motor mount screw to secure the motor and set the drive belt tension.



Fig. 61

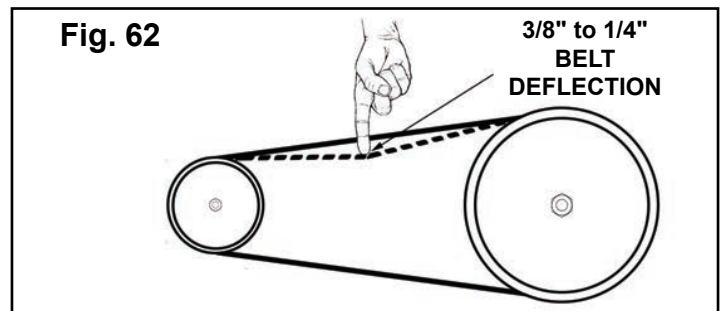

Fig. 62

CHANGING THE MOTOR DRIVE BELT

UNPLUG THE MACHINE FROM THE POWER SOURCE BEFORE CHANGING THE MOTOR DRIVE BELT. THE POWER SWITCH MUST BE OFF UNTIL ALL ADJUSTMENTS ARE MADE.

To change the drive belt:

1. Release the tension on the bandsaw blade and move the blade off the lower wheel, or remove it completely.
2. Loosen the top motor mount screw and pivot the motor to release tension on the drive belt **NOTE:**
3. Mark the top of the motor near the screw to help identify the belt tension point
4. Use C-Clip or "Snap Ring" pliers (not included) to remove the retaining clip in the middle of the wheel.
 - a. Carefully spread the retaining clip outwards with the pliers and remove clip. (Fig. 63) **DO NOT BREAK THE CLIP. DO NOT USE A LOT OF FORCE TO REMOVE IT.**
5. Slowly pull the wheel off the lower shaft.
6. Remove the old belt from the pulleys.
7. Install the new belt on the desired pulley and reverse the above steps. For different speeds, go to the above section.
8. Ensure the drive belt ribs are correctly seated in the pulley before reassembling and tensioning the belt.
9. Tension the drive belt to allow 3/8" to 1/2" deflection.



Fig. 62



Fig. 63

CHANGING BANDSAW TIRES

The bandsaw tire is a ring that fits around the wheel that acts as a protective cushion between the blade and wheel. This tire can get worn out with use and may need to be replaced.

To remove the old tire:

1. Loosen the blade tension.
2. Move the blade off the wheel or remove it completely.
3. Use a putty knife to lift the tire away from the wheel.
4. Work the knife around the wheel to loosen the tire.
5. Flip the tire off the wheel using the knife as leverage.
6. Clean the groove with rubbing alcohol. Ensure the groove is completely dry



Fig. 64

To Install the new tire:

1. Place the new tire in warm water for 1-5 minutes to make it more pliable.
2. Dry the tire completely and place it on the wheel while still warm.
3. Fit the tire on the wheel groove, starting at the top. A putty knife or round tool may need to be used to fit the tire on the wheel. **BE CAREFUL NOT TO CUT THE TIRE. PLACING A CLEAN RAG OVER THE PUTTY KNIFE BLADE MAY REDUCE CUTTING EXPOSURE.**

CHANGING THE BANDSAW BLADE

This bandsaw is factory-equipped and set with a general-purpose wood cutting blade. To change the saw blade, the following procedure must be followed:

⚠ WARNING! Unplug the machine from the electrical supply so it will not accidentally turn on while changing the saw blade.

1. Loosen the blade tension using the quick release tension lever.
2. Remove the throat plate.
3. Move the rip fence to the left so that it is out of the way of the throat plate.
4. Remove dust port from under the table by pulling down of the front edge to release magnet and slide the dust collection assembly forward.
5. Remove the table leveling bolt from the blade slot.
6. Open the top and bottom wheel doors.
7. Move the upper and lower blade guides away from the sides and rear of the saw blade.

⚠ CAUTION! BLADE IS SHARP, USE CAUTION WHEN HANDLING! WEAR CUT RESISTANT GLOVES FOR SAFE HANDLING.

Throat Plate

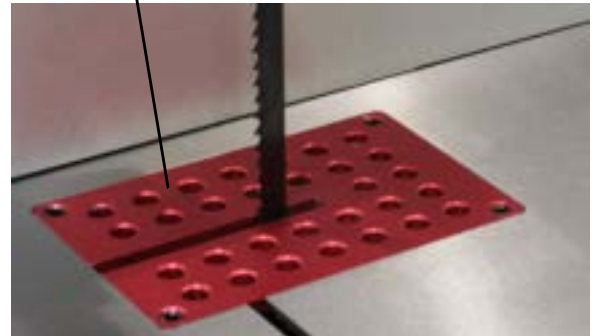

Fig. 65

7. Remove the saw blade from the top wheel, then feed it through the upper blade guides, table slot, lower blade guides, left slot in the column, and off the bottom wheel.
8. Install the new blade by reversing the steps 1-7. Ensure the blade teeth point downwards and towards you at the table.
9. Center the blade on both wheels.
10. Tighten the blade tension by moving the quick release lever to the right.
11. Adjust the final tension by rotating the tension knob on the top of the bandsaw.
12. Rotate the wheel and check the blade tracking and adjust if needed. Continue rotating wheel until blade is tracked.
13. Close and lock both wheel doors.
14. Reinstall the table leveling bolt.
15. Adjust the blade guides.
16. Reinstall the magnetic under-table dust port by sliding the port rearward under the table while centering the blade in the gap on the port. The rear magnets should be positioned in the flat area under the table and then the front magnets should snap into place under the table.
17. Reinstall the throat plate.
18. Adjust the fence for any fence drift.

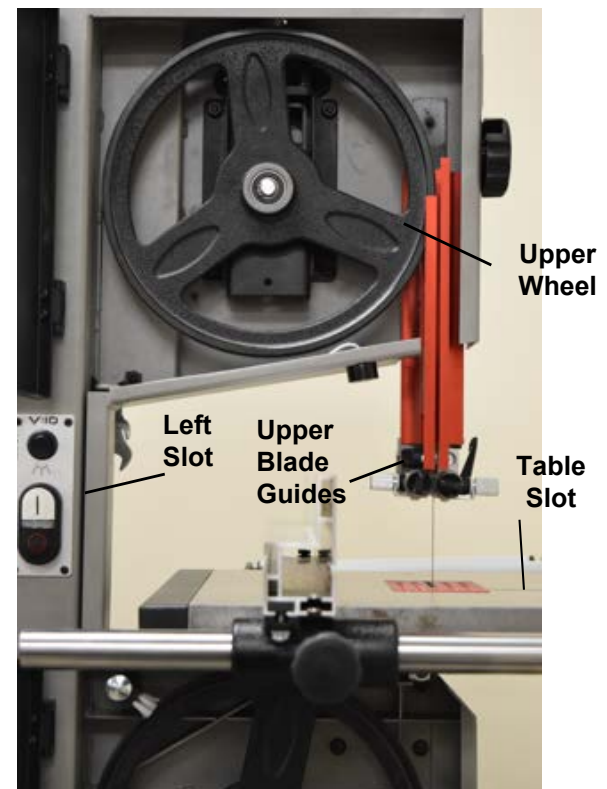

Fig. 66

ADJUSTING FOR DRIFT

Bandsaw drift is when a piece of wood being cut on a bandsaw wanders away from the fence or the intended straight line of the cut.

To adjust for drift:

1. Make a test cut part way into a piece of wood that is moved against the rip fence, stopping the saw with the blade still in the cut and observing the distance between the rear edge of the blade and the wood.
2. The fence can then be adjusted to the left or right when the wood is removed.
3. Once the fence is adjusted, the fence should be moved over to start a new cut to observe that the rear edge of the blade is centered in the kerf.
4. If it is centered, then the adjustment is complete.
5. If it is still not centered, repeat as necessary until the rear edge of the blade is centered in the kerf.

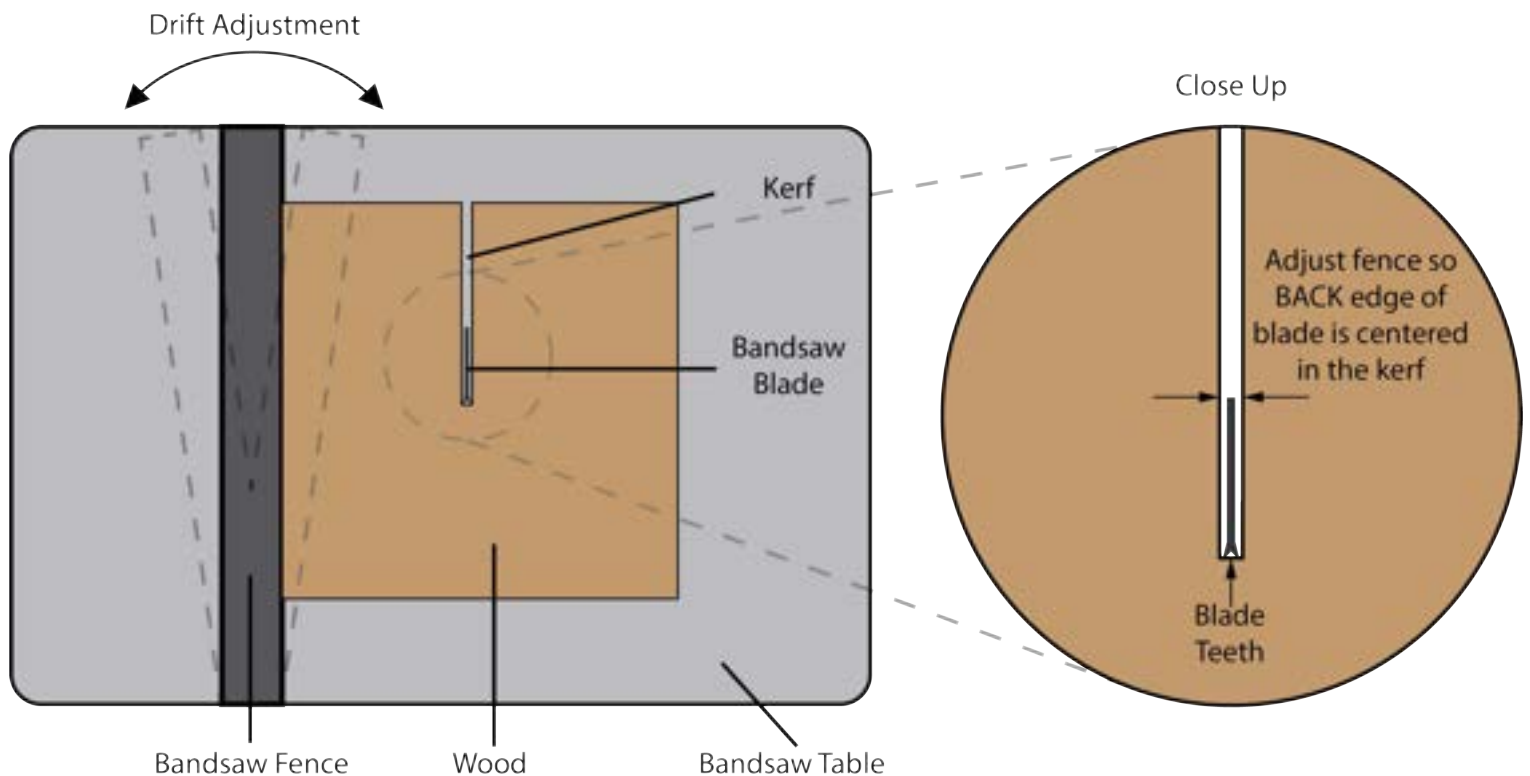

TEST RUN

Before starting the machine

Read and understand the manual before operating the saw.

1. If unsure how to use the bandsaw, consult a qualified professional.
2. Ensure proper grounding and code-compliant wiring.
3. Never operate under the influence or when tired.
4. Use eye, hearing, and dust protection.
5. Remove jewelry, ties, and roll up sleeves.
6. Always keep blade guards in place.
7. Blade teeth should face down; adjust guard close to the material.
8. Ensure proper blade tension and tracking.
9. Ensure upper and lower guides are properly adjusted and secure.
10. Ensure desired speed is selected and drive belt is seated securely on pulleys.
11. Ensure that trunnion degree scale is set to 0°.
12. Examine workpiece to make sure it is suitable for cutting.
13. Use the correct blade type and size.
14. Plug in the saw to a 120V power source.
15. Turn on the light on the bandsaw.
16. Turn on the machine by pressing the ON button.
17. Keep hands away from the blade.
18. Hold workpiece firmly; support uneven stock.
19. Use a push stick at the end of cuts.
20. Feed material steadily at a moderate speed.
 - a. If using a new blade, slowly make first two or three cuts with slight pressure, doubling the usual cutting time. This will break in the new blade. This will ensure the blade's quality and lifespan.
21. Turn off the saw and wait for the blade to stop before backing out of a cut.
22. Turn off the saw and wait for blade to stop before removing scraps.
23. Examine workpiece and ensure that blade is cutting straight.
24. If there are no issues or adjustments that need to be made, the saw is now ready for use.

USING THE BANDSAW

Bandsaws are great for curves and straight cuts, including ripping. Bandsaw possess these attributes:

- Safer than radial arm saws due to downward cutting force, reducing kickback.
- Ideal for thick stock and minimizing wood waste, especially with expensive materials.
- Surface finish is rougher than other saws, but using a Laguna Resaw King blade improves cut quality, reduces waste, and lasts longer. The Laguna Resaw King Blade is carbide-tipped and can be resharpened. [part no. BBRK-12-7012]



Fig. 67

Ripping Techniques

Ripping follows the wood grain; common types include rip, bevel, taper, and resaw cuts.

Two methods for straight cuts:

- Use the widest blade that the saw will accept, for the V:10 bandsaw it is a 1/2" blade.
- Rip Fence: Recommended for accuracy and efficiency, especially for repeated cuts. Correctly adjusting the fence to the dynamic way that the specific blade is cutting as described above will give the best quality of cuts.

SELECTING A BLADE

Using a Radius Chart

When you're new to using a saw, refer to a radius (contour) chart to choose the right blade size for cutting curves. These charts, found in woodworking books, articles, and blade packaging, offer general guidance on how tight a curve each blade can handle. While they vary slightly and aren't perfectly accurate due to differences in saws and operators, they're useful starting points.

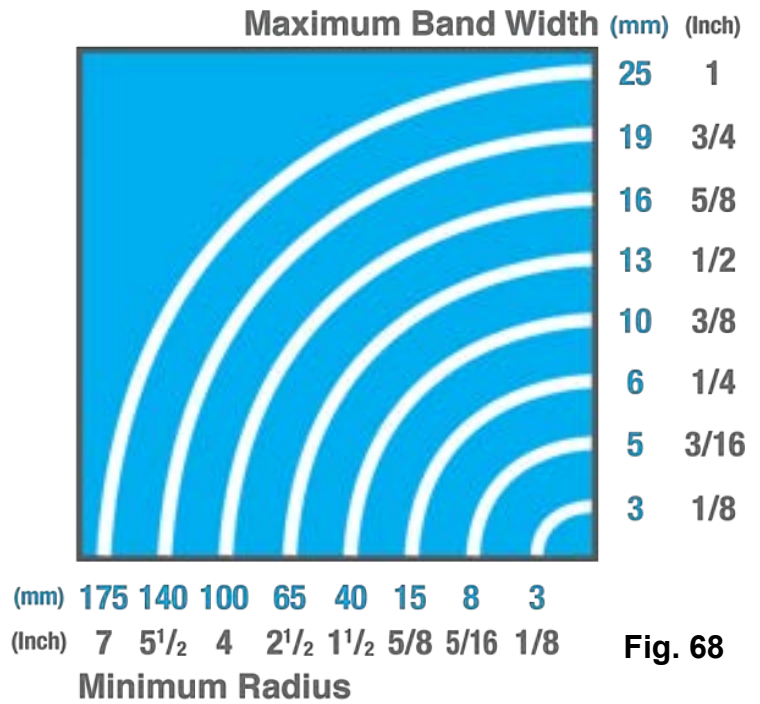

Fig. 68

Different sizes and types of blades are listed below

1. 1/4" 6 TPI. This is a small, aggressive blade that is suitable for tight curves and fast cutting where a good surface finish of the cut is not important.
2. 1/4" 14 TPI. This is a small, fine blade suitable for reasonably tight cuts where the surface finish is important, but speed of cut is less important.
3. 1/2" 3 TPI. This is a general-purpose blade that can cut large radiuses and short sections of straight cuts. The cut is fast, and the surface finish of the cut is poor.
4. 1" 2 TPI. This is a resaw blade, which will be used for straight cuts and is suitable for processing veneers.
5. If you are going to be cutting hardwoods or require superb surface finish, then you should consider purchasing a Resaw King blade from Laguna.

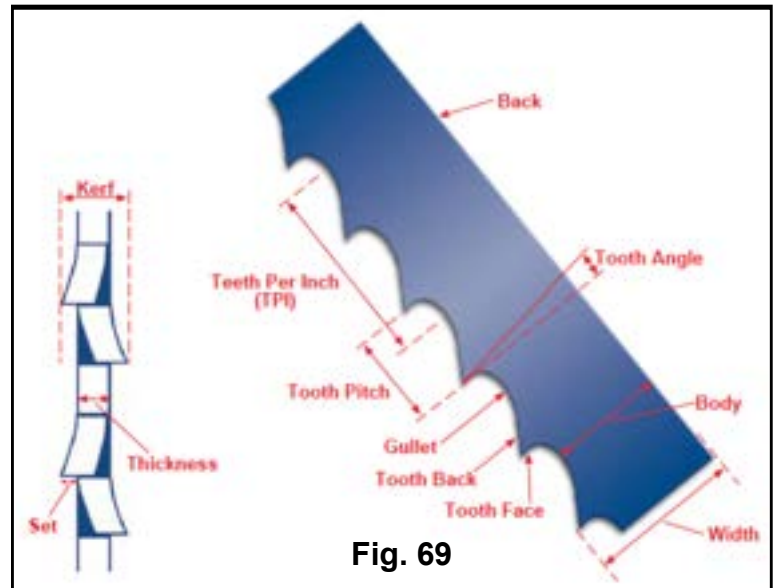

Fig. 69

Bandsaw-blade tooth configurations

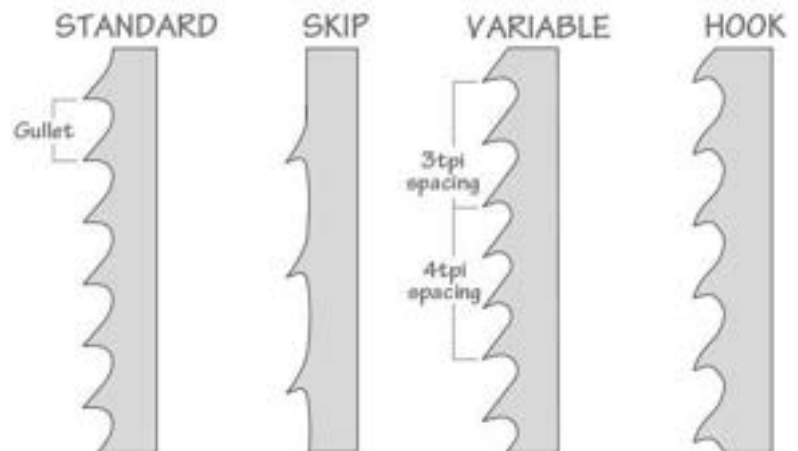

Fig. 70

HOW TO COIL A BANDSAW BLADE



CAUTION! BLADE IS SHARP, USE CAUTION WHEN HANDLING! WEAR CUT RESISTANT GLOVES FOR SAFE HANDLING.

Below are easy-to-follow instructions on folding a blade.

Method One

While wearing a jacket or long-sleeved shirt and gloves, hold the blade in front of you in one large loop, with the teeth facing towards you. Place your foot on the blade, holding it on the ground. Grasp the blade with both hands, with your thumbs to the outside, at approximately the 10 o'clock and 2 o'clock positions (Step 1). Slowly twist the top of the blade away from your body (Step 2). Bring your hands together to form two loops while folding down (Step 3). Continue rotating the blade until you form three loops.

Note. It is recommended that the blade is placed on material that will not damage the blade teeth (wood or cardboard). Your foot is there to give stability and not to clamp the blade, so do not exert excessive force, or the teeth/band may be damaged. The photographs are shown without gloves to enable the hand/thumb position to be shown. Gloves must be worn, as the blade could cause injury.



Step 1



Step 2



Step 3

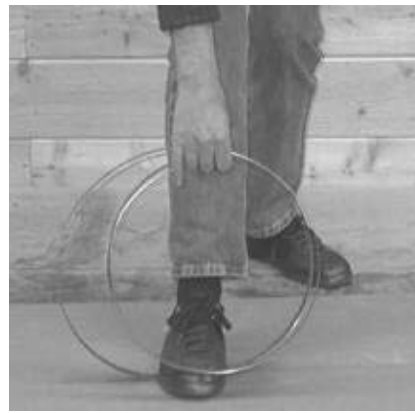

Done

Method Two

There is another variation of this that works well with small blades but simply is not possible for larger bandsaw blades, unless you're very big and strong. This method works the same as the method above, but rather than holding the blade with both hands, grasp the blade at the top while holding the bottom of the blade with your foot (teeth still facing away from you). Grasp the blade with your hand, twisting your arm such that your elbow is facing away from your body (Step 1). Turn the palm of your hand toward your body about 180 degrees and then continue turning while pushing down on the blade (Steps 2, 3 and 4). The blade will fold down upon itself into three circles, lying flat on the ground (Done).



Step 1



Step 2

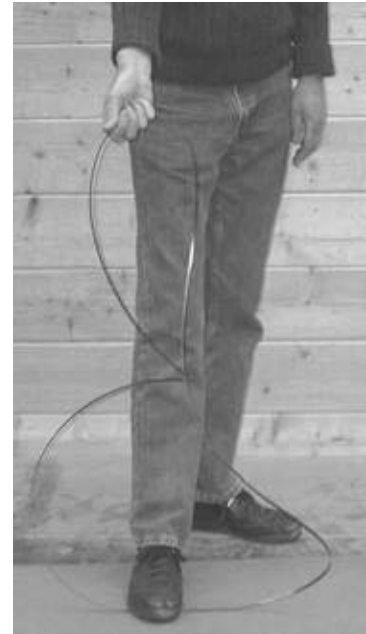

Step 3



Step 4



Done

Method Three

The steering wheel method. Start with the blade in front of you. as if you're holding a steering wheel with your hands at the 9 o'clock and 3 o'clock positions. Simultaneously twist your left hand up and your right hand down. As the blade starts to fold, move your hands closer together while tilting your left hand to the right and your right hand to the left. The blade will fall into three coils. A variation of this method is to hold the blade as above, but twist both hands inward so you're looking at your knuckles and the blade will again fall into three coils.



Step 1



Step 2



Step 3



Step 4



Done

Maintenance and Troubleshooting

Performing regular maintenance will ensure optimal performance of the machine. Please follow these maintenance procedures. Failure to follow maintenance procedures will void the warranty

This maintenance table is based on 30 hours of use

Maintenance Task	Frequency	Details
Clean the Bandsaw	After each use	Remove sawdust and debris from the table, blade, and wheels.
Check Blade Tension	Before each use	Ensure the blade is properly tensioned for accurate cuts.
Inspect Blade for Wear	Weekly	Look for signs of dullness, cracks, or damage. Replace if necessary.
Lubricate Moving Parts	Monthly	Apply lubricant to the blade guides, bearings, and other moving parts.
Check Wheel Alignment	Monthly	Ensure the upper and lower wheels are aligned for proper blade tracking.
Inspect Electrical Components	Quarterly	Check the power cord, switch, and motor for any signs of wear or damage.
Replace Blade	As needed	Replace the blade when it becomes dull or damaged.
Check and Adjust Blade Guides	Monthly	Ensure the blade guides are properly aligned and adjusted.
Inspect and Clean Dust Collection	Monthly	Check and clean the dust collection system to ensure proper operation.
Check Table Alignment	Quarterly	Ensure the table is square to the blade for accurate cuts.

Maintenance Task	Frequency	Details
Inspect Drive Belt	Monthly	Check the drive belt for wear and tension. Replace if necessary.
Clean and Inspect Tires	Monthly	Clean the tires and check for wear. Replace if necessary.
General Cleanliness	Weekly	Keep the entire bandsaw clean to prevent buildup of debris and dust.

Troubleshooting Table

Issue	Possible Causes / Actions
Bandsaw will not start	<ol style="list-style-type: none"> 1. Check the main power switch on the rear of the saw 2. Ensure the light in the center of the ON/OFF switch is on, then press the top ON button firmly. 3. Check power cord connection. 4. Check and reset the shop circuit breaker. 5. Ensure correct voltage (120V, not 220V).
Machine will not stop	<p><i>Rare occurrence; machine is designed to be fail-safe. Disconnect from power and seek help.</i></p> <ol style="list-style-type: none"> 1. Stop switch faulty – replace. 2. Internal breaker faulty – replace.
Motor tries to start but will not turn	<ol style="list-style-type: none"> 1. Disconnect power and try turning wheel by hand; check for jams (tight guides, wood stuck). 2. Replace faulty capacitor. 3. Replace faulty motor.
Motor overheats	<p><i>Motor has overload protection and will auto-reset.</i></p> <p>If overheating persists:</p> <ul style="list-style-type: none"> - Check for dull blade. - Avoid overfeeding. – Inspect cooling fan and fins for clogs. - Check ambient temperature.

Issue	Possible Causes / Actions
Squeaking noise	<ol style="list-style-type: none"> 1. Check for loose or glazed drive belt. (most common cause of squeaking) 2. Inspect bearings. 3. Check drive belt. 4. Ensure guides are adjusted properly.
Upper guide shaft is tight or loose	<ol style="list-style-type: none"> 1. Clean and lubricate. 2. Adjust rack and pinion. 3. Replace bent rack.
Blade slows down during a cut	<ol style="list-style-type: none"> 1. Re-tension loose drive belt. 2. Replace or resharpen dull blade. 3. Reduce feed rate. 4. Use blade with correct tooth set. 5. Clean or replace dirty/oily drive belts. 6. Align fence properly.
Blade will not track on flywheels	<ol style="list-style-type: none"> 1. Replace bad blade. 2. Dress tires if crown is worn/damaged.

Issue	Possible Causes / Actions
Blade kicks	Bad blade – replace it.
Blade makes a clicking noise	Bad weld – dress the weld or replace blade.
Blade overheats	<ol style="list-style-type: none"> 1. Replace or sharpen dull blade. 2. Use blade with correct pitch. 3. Adjust overly tight guides. 4. Use appropriate blade for wood hardness. 5. Use thinner blade if wheels are too small.
Machine vibrates	<ol style="list-style-type: none"> 1. Re-level the machine. 2. Replace damaged drive belt.

Issue	Possible Causes / Actions
<p align="center">Blade Dulling Fast</p>	<ol style="list-style-type: none"> 1. Poorly set side guides or rear thrust guide. 2. Poor tracking. 3. Wrong blade selection. If the blade is too narrow, it will flex more easily and decrease the quality of the cut. The blade should also have the correct pitch and width. 4. The tooth pitch is too fine (too many teeth per inch). 5. Certain woods will dull a steel blade very quickly, especially tropical hardwoods (teak, koa, etc.). Other woods with a high silicon content will also dull the blade quickly; even a cut as short as 6" will cause damage to the blade. 6. On certain exotic woods, the ends have been painted. This is done to control the drying. The paint is very abrasive and will dull the blade as you cut through it. It is recommended that you cut the painted ends off your wood.
<p align="center">Causes of Blade Breakage</p>	<ol style="list-style-type: none"> 1. Excessive blade thickness in relation to the flywheel diameter. 2. Defective welding. 3. Incorrect tension, particularly if the blade is over tensioned; the tension spring no longer fulfills its function. 4. After use it is recommended that you slacken the tension, especially overnight (placing a visible notice of this operation). 5. Misalignment of the flywheels. 6. Irregularity of flywheel surface, for instance, an accumulation of sawdust while cutting resinous materials. <p>You can correct these problems by readjusting the machine, changing the way you operate it or by changing the blade. Try only one change at a time.</p>

CAUTION! READ AND UNDERSTAND THESE STEPS BEFORE MAKING ANY ADJUSTMENTS. FAILURE TO DO SO COULD DAMAGE THE MACHINE.

LOWER WHEEL ADJUSTMENTS

Adjusting the lower wheel's alignment with the upper wheel will correct blade position and oscillation (wobble), which are critical for the bandsaw's performance and accuracy.

Release the blade tension completely before adjusting the lower wheel to ensure proper adjustments and prevent machine damage.

If the blade runs off-center on the lower wheel but is correct on the upper wheel, the flywheel assembly will need to be adjusted. Use the clock face positions (12, 3, 6, 9) for easy identification.

NOTE: Mark a white dot on the bolt's edge to visually track how much the bolt has been adjusted.

The 12 and 6 o'clock positions adjust the forward and back wheel position to help align the blade

The 9 and 3 o'clock positions adjust the left and right wheel position to help align the blade.

If the blade tracks **forward on the lower wheel toward the door**, follow these steps below. This is a very common blade tracking issue.

1. Loosen the tension on the saw blade.
2. Loosen the 9 o'clock lock nut to relieve pressure.
3. Loosen the 12 o'clock lock nut and adjust the bolt by half a rotation.
4. Tighten the 6 o'clock lock nut and adjust the shaft bolt until it touches the 12 o'clock adjusting bolt.
5. Tighten and secure lock nuts.
6. Tighten the saw blade and adjust the upper wheel by using the tracking knob.
7. Spin the upper wheel by hand to track the blade.
8. Ensure blade looks like Figure 72 and repeat if further adjustment is needed.
9. For other adjustments, determine the position the wheel needs to be at, and adjust the corresponding bolts.

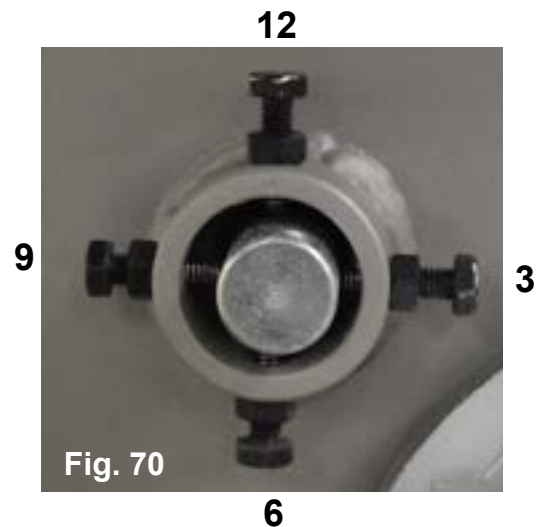

If a bandsaw blade is wobbling, follow these steps:

1. Inspect the blade and ensure it has been welded correctly and lies flat when placed on a table.
2. Loosen the tension on the saw blade.
3. Loosen the 6 o'clock lock nut.
4. Loosen the 9 o'clock lock nut and adjust the bolt half a turn.
5. Loosen the 3 o'clock lock nut and adjust the bolt until it touches the 9 o'clock bolt.
6. Tighten all three lock nuts
7. Tighten the tension on the saw blade and adjust the upper wheel by using the tracking knob.
8. Spin the upper wheel by hand to track the blade.
9. Start the bandsaw and inspect blade movement and tracking.
10. If movement improves, continue adjusting.
11. If movement worsens, reverse steps 3 and 4.
12. Ensure the blade is in the middle of the throat plate.

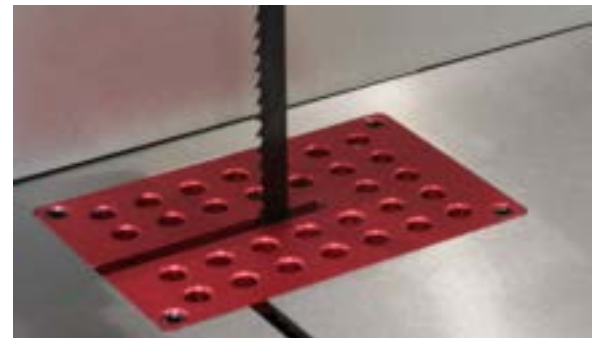
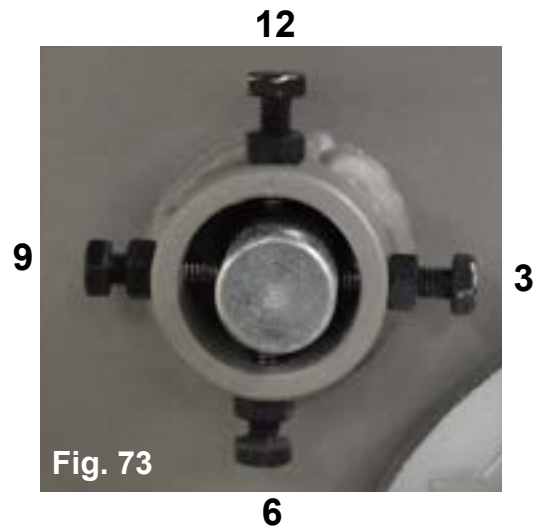

ELECTRICAL DRAWING

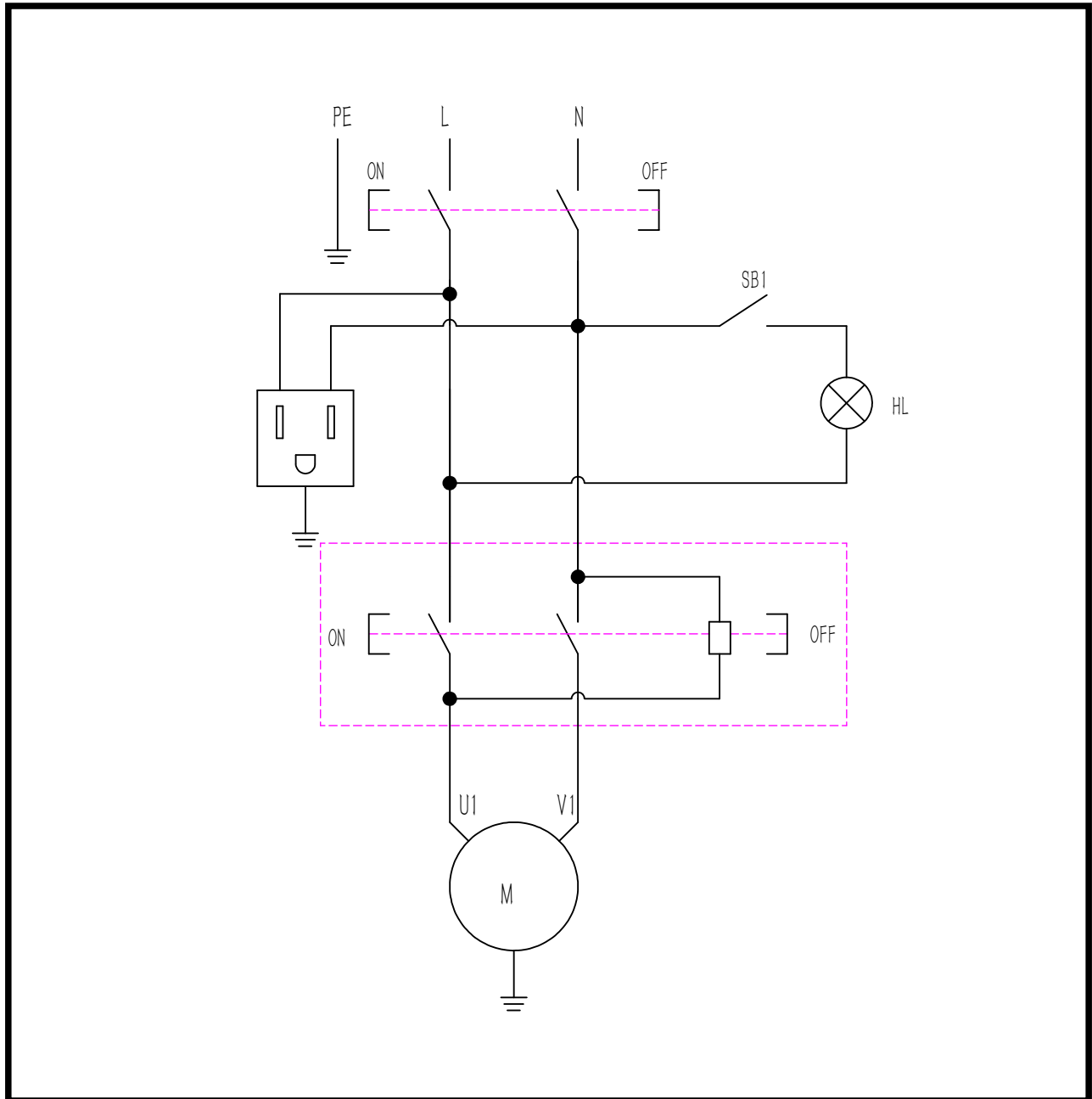

EXPLODED VIEW DRAWINGS & PARTS LISTS

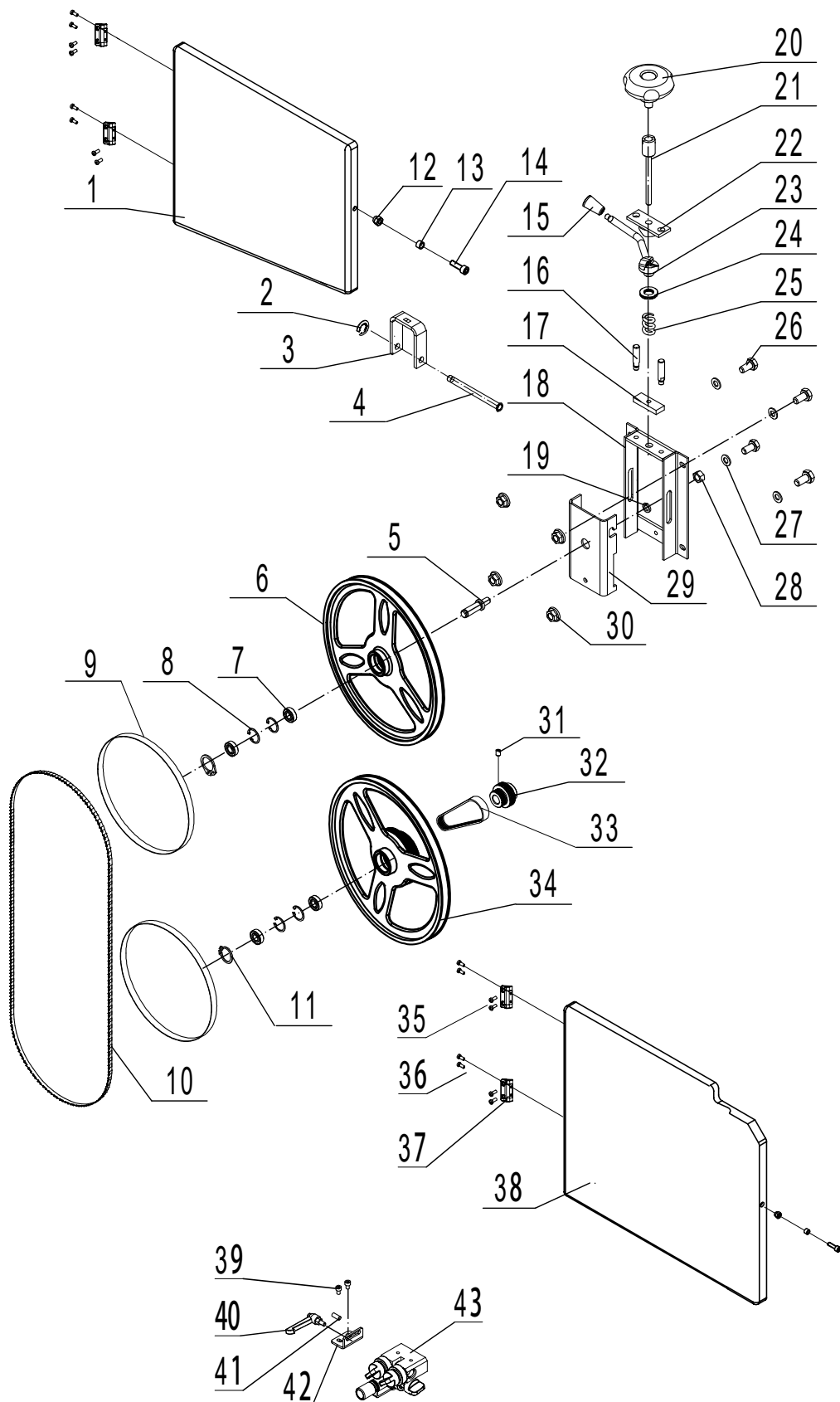

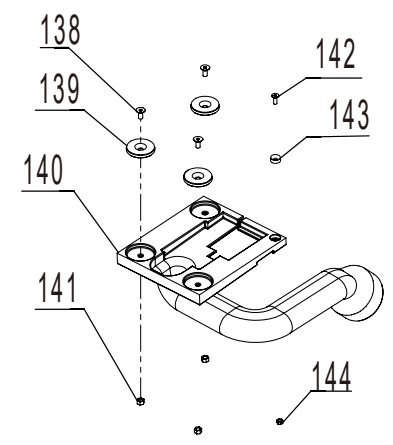
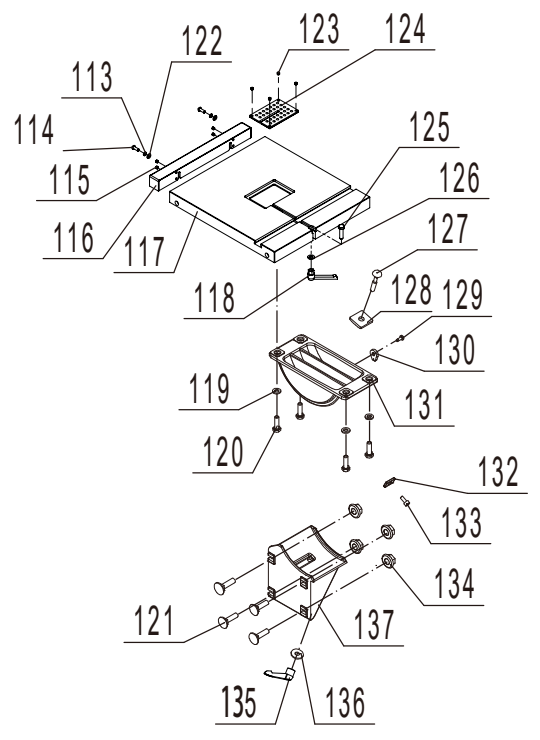
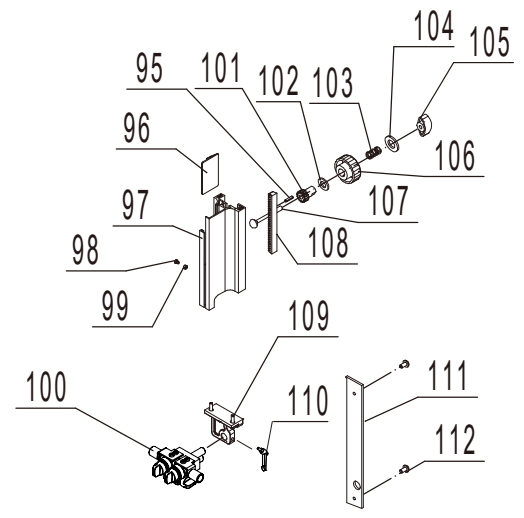
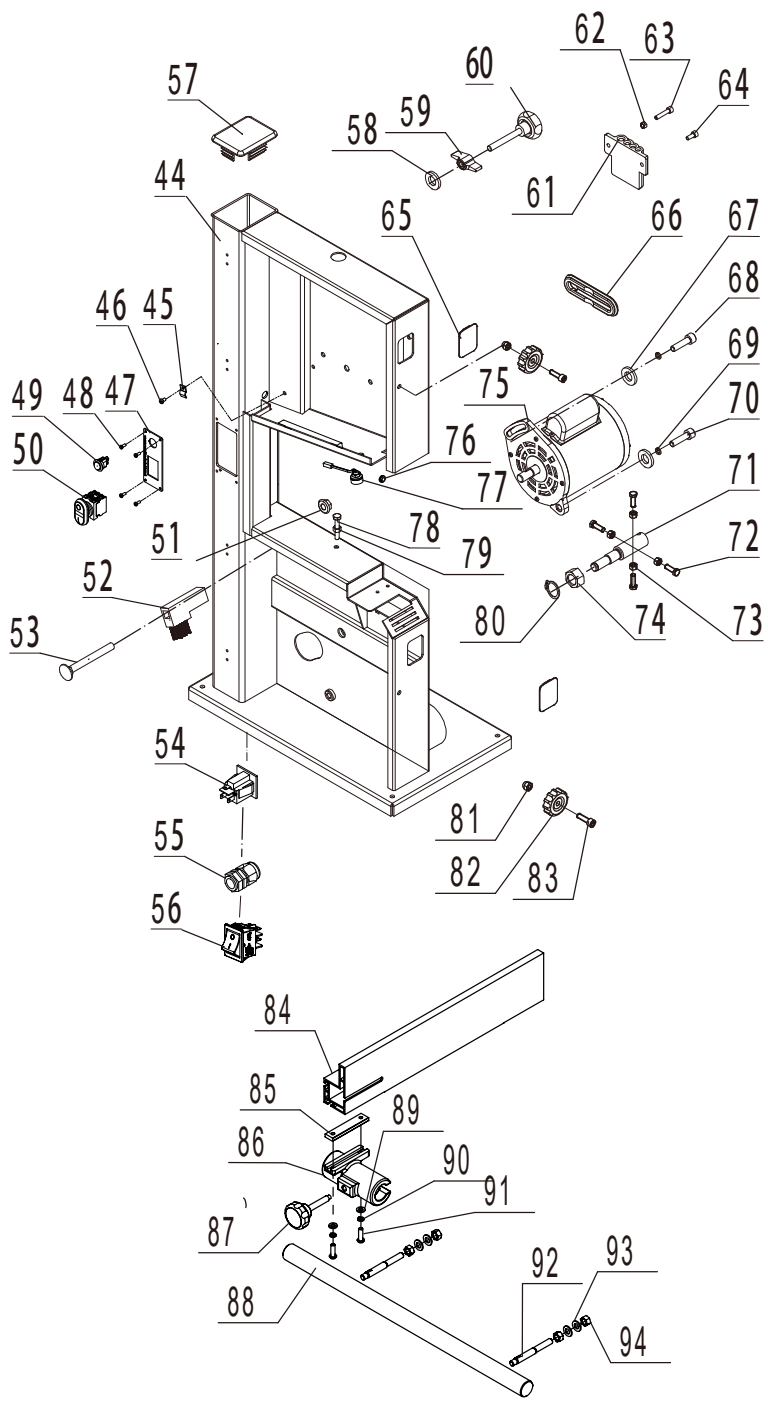

No.	Description	Part No.	Spec	Qty
PBAND10V-1	Upper door	1-JMBS1001013001D-001Z		1
PBAND10V-2	Retaining Ring	1-CLP6GB896B	6	1
PBAND10V-3	U-support	1-JMBS1001041003-001Z		1
PBAND10V-4	Guide bearing	1-JL22021002		1
PBAND10V-5	Upper wheel bearing	1-JMBS1001041001		1
PBAND10V-6	Upper wheel	1-JMBS1001021001A-001Z		1
PBAND10V-7	Bearing	1-BRG6001-2RSGB276	6001	4
PBAND10V-8	Retaining Ring	1-CLP28GB893D1B	28	4
PBAND10V-9	Rubber ring	1-JMBS1001020003		2
PBAND10V-10	Blade	1-JL22020001A		1
PBAND10V-11	Retaining rings for A bearing	1-CLP12GB894D1B	12	2
PBAND10V-12	Hexagonal Lock Nuts	1-M6GB889D1Z	M6	2
PBAND10V-13	Spacer	1-JMBS1001010008		2
PBAND10V-14	Hex Head Cap Screw	1-M6X25GB70D1Z	M6X25	2
PBAND10V-15	Handle Tube	1-JXPT1201020007-001S		1
PBAND10V-16	Positioning bolts	1-JMBS1001041010		2
PBAND10V-17	Locking plate	1-JMBS1001041004		1
PBAND10V-18	Tensioner Welding Assembly	1-JMBS1001041100-001Z		1
PBAND10V-19	Standard Spring Washer	1-WSH10GB93B	M10	1
PBAND10V-20	Tension handle	1-JMBS1001043001-001S		1
PBAND10V-21	Tension bar assembly	1-JMBS1001042000		1
PBAND10V-22	upper cam	1-JMBS1001041201		1
PBAND10V-23	Lower cam assembly	1-JMBS1001041300		1
PBAND10V-24	Bearing	1-BRG1528AXKASGB4605	1528AXKAS	1
PBAND10V-25	Press Spring	1-JMBS1001041002		1
PBAND10V-26	Hex Bolt	1-M6X12GB5783B	M6X12	4
PBAND10V-27	flat washer	1-WSH6GB97D1B	M6	4
PBAND10V-28	Hex Nut	1-M10GB6170B	M10	1
PBAND10V-29	Connecting plate for upper wheel bearing	1-JMBS0901040008-001Z		1
PBAND10V-30	Flange Nuts	1-M6GB6177D1B	M6	4
PBAND10V-31	Hex Socket Set Screw	1-M6X12GB77B	M6X12	2
PBAND10V-32	Motor Pulley	1-JMBS1001020002		1
PBAND10V-33	Poly V-Belt	1-4PJ381GB16588	4PJ-381	1
PBAND10V-34	Lower wheel	1-JMBS1001022101B-001Z		1
PBAND10V-35	Cross Recessed Pan Head Screw	1-M4X10GB818B	M4X10	8
PBAND10V-36	Cross Recessed Pan Head Screw	1-M4X6GB818B	M4X6	8
PBAND10V-37	Hinge	1-JMBS1001013100		4
PBAND10V-38	Lower door	1-JMBS1001014001D-001Z		4
PBAND10V-39	Hexagon round screw	1-M5X10GB70D2B	M5X10	2
PBAND10V-40	Adjustment handle(zinc- aluminum alloy)	1-KTSB-1-B-M6X50X10		1
PBAND10V-41	Hex Socket Set Screw	1-M6X12GB77B	M6X12	1
PBAND10V-42	Lower guide Connecting Plate	1-JMBS1001010006-182Z		1
PBAND10V-43	Lower guide assembly	1-JMBS1001012000B		1
PBAND10V-44	Frame	1-JMBS1001011000D-182Z		
PBAND10V-45	Cable clamp (single head, fine wire)	1-1502014-02		1
PBAND10V-46	Cross Recessed Pan Head Screw	1-M5X10GB818B	M5X10	1
PBAND10V-47	Control plate	1-JMBS1001010012		1
PBAND10V-48	Small Cross Recessed Pan Head Screw	1-M4X10GB823B	M4X10	4
PBAND10V-49	Switch for LED light	1-TH13-D-S88B-A7BA-D		1
PBAND10V-50	Electromagnetic switch	1-DZ04-2		1

PBAND10V-51	Hexagona Flange Nuts	1-M8GB6177B	M8	1
PBAND10V-52	Cleaning Brush	1-JL22010006		1
PBAND10V-53	Bolt	1-M8X70GB14Z	M8X70	1
PBAND10V-54	socket(UL certificate)	1-DB-F-M		1
PBAND10V-55	Strain Relief	1-JL20072101/1-JL20072102		1
PBAND10V-56	Simple push switch	1-AN07		1
PBAND10V-57	Top Plug	1-JL22010001A-001S		1
PBAND10V-58	Large Washer (Class A)	1-WSH8GB96D1B	M8	1
PBAND10V-59	Wing Nut	1-JL20010016-001S		1
PBAND10V-60	Plastic round Handle	1-JMBS1403060003-001S		1
PBAND10V-61	tool holder	1-JL26090001		1
PBAND10V-62	Hex Nut	1-M5GB6170B	M5	1
PBAND10V-63	Hex Head Cap Screw	1-M5X25GB70D1B	M5X25	1
PBAND10V-64	Hex Head Cap Screw	1-M5X12GB70D1B	M5X12	1
PBAND10V-65	Windows	1-JMBS1001010004		2
PBAND10V-66	Dust cover	1-JMBS1001010005		1
PBAND10V-67	Large Washer (Class A)	1-WSH8GB96D1B	M8	2
PBAND10V-68	Screw	1-M8X30GB70D1B	M8X30	1
PBAND10V-69	Standard Spring Washer	1-WSH8GB93B	M8	2
PBAND10V-70	Screw	1-M8X30GB70D1B	M8X30	1
PBAND10V-71	Lower wheel bearing	1-JMBS1001020001		1
PBAND10V-72	Hex Bolt	1-M6X20GB5783B	M6X20	4
PBAND10V-73	Hex Nut	1-M6GB6170B	M6	4
PBAND10V-74	Nut	1-M14GB6171Z	M14	1
PBAND10V-75	Motor	2-YYH718054A		1
PBAND10V-76	Wire cover	1-JL60010004		1
PBAND10V-77	LED Ligh ^{assembly}	1-JMBS1001019000		1
PBAND10V-78	Screw	1-M6X35GB5781B	M6X35	1
PBAND10V-79	Nut	1-M6GB6170B	M6	1
PBAND10V-80	Type A Circlip	1-CLP12GB894D1B	12	2
PBAND10V-81	Hex Nut	1-M6GB889D1Z	M6	2
PBAND10V-82	Door Handle	1-JL26010006-001S		2
PBAND10V-83	Hex Head Cap Screw	1-M6X20GB70D1Z	M6X20	2
PBAND10V-84	Fence assembly	1-JMBS1001060009A		1
PBAND10V-85	Locking plate	1-JMBS1601060002		1
PBAND10V-86	Handlebar	1-JL28060009A-001G		1
PBAND10V-87	Locking handle	1-JL82450006		1
PBAND10V-88	Front Guide Rail	1-JMBS1001060001A		1
PBAND10V-89	Flat washer	1-WSH6GB97D1B	M6	2
PBAND10V-90	Spring washer	1-WSH6GB93B	M6	2
PBAND10V-91	Hexagon round screw	1-M6X20GB70D2B	M6X20	2
PBAND10V-92	Support roller	1-JL28060005A		2
PBAND10V-93	Flat washer A Class	1-WSH8GB97D1B	M8	4
PBAND10V-94	Hex Nut	1-M8GB6170B		4
PBAND10V-95	Pin	1-PIN3X10GB879D1B	M3X10	1
PBAND10V-96	Sliding Plate	1-JMBS0901050010A-001S		1
PBAND10V-97	Upper guide sliding Plate	1-JMBS1001050003C		1
PBAND10V-98	Cross Recessed Pan Head Screw	1-M3X5GB818Z	M3X5	1
PBAND10V-99	Screw	1-M3GB6170B	M3	1
PBAND10V-100	Upper guide assembly	1-JMBS1001051000B		1

PBAND10V-101	Gear wheel	1-JMBS0901050005A		1
PBAND10V-102	Adjusting Plate	1-JL40020004		1
PBAND10V-103	Spring	1-JMBS0901050016		1
PBAND10V-104	Flat washer A class	1-WSH6GB96D1B	M6	1
PBAND10V-105	Locking handle	1-JMBS0901050015-001S		1
PBAND10V-106	Lifting Handle	1-JMBS0901050007A-001S		1
PBAND10V-107	square headed bolt	1-M6X50GB12B	M6X50	1
PBAND10V-108	Rise & Fall Rack	1-JMBS1001050001A		1
PBAND10V-109	Support block	1-JMBS1001050002A		1
PBAND10V-110	Adjustment handle(zinc- aluminum alloy)	1-JMBS1001051009-001S		1
PBAND10V-111	position plate	1-JMBS1001010001A		1
PBAND10V-112	Cross Recessed Pan Head Screw	1-M5X10GB818B	M5X10	2
PBAND10V-113	Spring washer	1-WSH6GB93B	M6	2
PBAND10V-114	Hexagon round screw	1-M6X16GB70D2B	M6X16	2
PBAND10V-115	Hex Socket Set Screw	1-M6X5GB77B12D9	M6X16	3
PBAND10V-116	Extension Table Assembly	1-JMBS1001032003-001Z	M6X5	1
PBAND10V-117	Table	1-JMBS1001032001A		1
PBAND10V-118	Adjustment handle	1-KTSB-1-B-M6X50X10		1
PBAND10V-119	External tooth washer	1-WSH6GB862D2B	M6	4
PBAND10V-120	Hex Bolt	1-M6X12GB5783B	M6X12	4
PBAND10V-121	Bolt	1-M6X16GB14B	M6X16	4
PBAND10V-122	Flat washer	1-WSH6GB97D1B	M6	2
PBAND10V-123	Hex Socket Set Screw	1-M6X5GB77B12D9	M6X5	4
PBAND10V-124	Aluminium insert	1-JMBS1001032002A		1
PBAND10V-125	Hex Bolt	1-M8X30GB5781B	M8X30	1
PBAND10V-126	Flat washer	1-WSH6GB97D1B	M8	1
PBAND10V-127	Bolt	1-M6X35GB12Z	M6X35	1
PBAND10V-128	Sliding Block	1-JMBS1001031003		1
PBAND10V-129	Screw	1-ST3D5X9D5GB845B	ST3D5X9D5	1
PBAND10V-130	Pointer	1-1506003		1
PBAND10V-131	Trunnion	1-JMBS1001031002A		1
PBAND10V-132	Block	1-JMBS1001031001-001S		1
PBAND10V-133	Hex Head Cap Screw	1-M4X10GB70D1B	M4X10	1
PBAND10V-134	Flange Nuts	1-M6GB6177D1B	M6	4
PBAND10V-135	Adjustment handle	1-KTSB-1-A-M6X50		1
PBAND10V-136	Flat washer	1-WSH6GB97D1B	M6	1
PBAND10V-137	Trunnion Support assembly	1-JL22030001B		1
PBAND10V-138	Hexagon round screw	1-M8X16GB70D2B	M6X16	6
PBAND10V-139	Flat washer A class	1-WSH6GB96D1B	M6	12
PBAND10V-140	Dust Chamber	1-JMBS1001131003		3
PBAND10V-141	Support	1-JMBS1001131001-001Z		1
PBAND10V-142	Washer	1-WSH8GB96D1B	M8	2
PBAND10V-143	Hexagon round screw	1-M8X16GB70D2B	M8X16	2
PBAND10V-144	Hex Socket Countersunk Head Screw	1-M5X12GB70D3B	M5X12	3
PBAND10V-145	Magnet (large)	1-JXPS1201052010		3
PBAND10V-146	Dust port	1-JMBS1001032004		1
PBAND10V-147	Hex Nut	1-M5GB6170B	M5	3
PBAND10V-148	Hex Socket Countersunk Head Screw	1-M4X12GB70D3B	M4X12	1
PBAND10V-149	Magnet	1-JMWL1203010006		1
PBAND10V-150	Hex Socket Countersunk Head Screw	1-M4GB6170B	M4	1

RETRACTABLE SWIVEL CASTERS - Set of 4

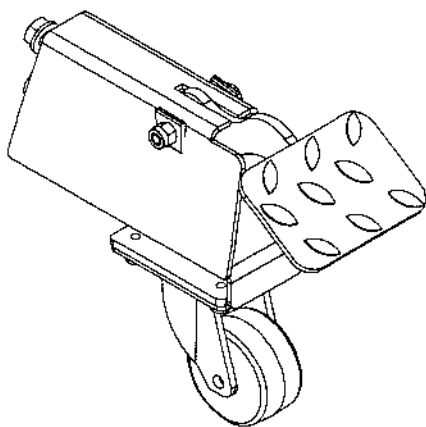
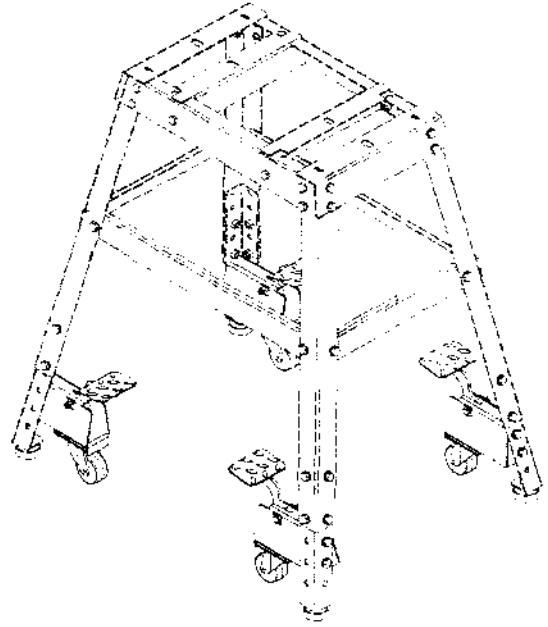
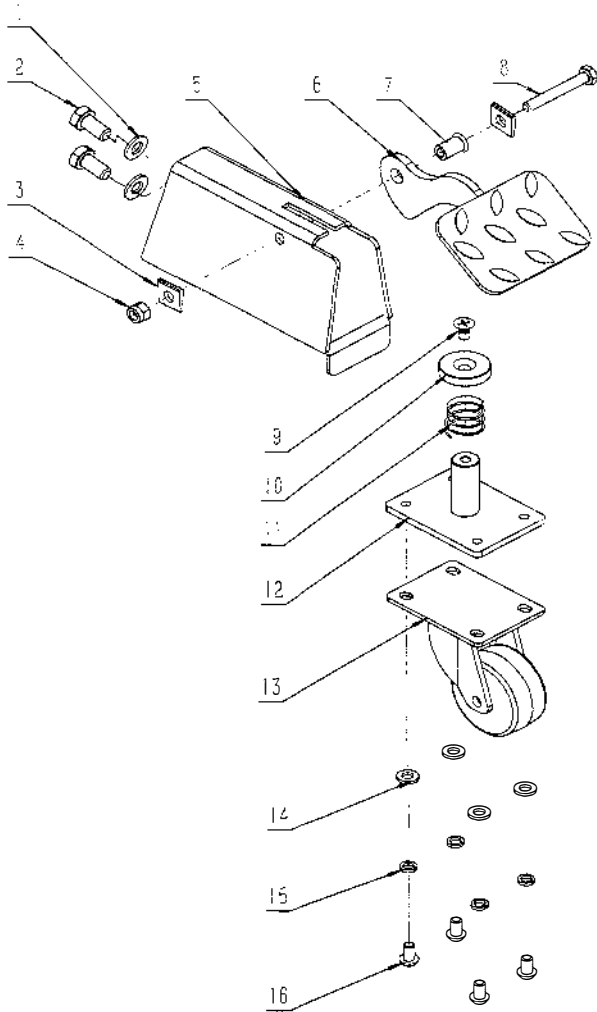

NO.	Description	Drawing Number
1	WSH8GB97D1B	Flat washer
2	M8X16GB5783B	screw
3	WSH6GB852B	washer
4	M6GB889D1Z	locking nut
5	WL1014A122000-001Z	Welded part for wheel kit
6	WL1014A123000-001Z	Pedal assy
7	M6X15GB17880D2Z	Nut
8	M6X45GB5781Z	screw
9	M6X10GB819D1Z	screw
10	WL1014A120001	Nut
11	JXPT1201090002	spring
12	WL1014A121000	Caster frame
13	WL1014A120003	2" All-direction wheel
14	WSH6GB97D1B	Flat washer
15	WSH6GB93B	spring washer
16	M6X10GB70D2B	screw

LAGUNA

LAGUNA TOOLS

744 Refuge Way, Suite 200 Grand Prairie, TX 75050

Ph: 1.800.234.1976 | www.lagunatools.com

Laguna Tools is not responsible for errors or omissions.
Specifications subject to change. Machines may be shown with optional accessories.

© 2025, Laguna Tools, Inc. LAGUNA® and the LAGUNA Logo® are the
registered trademarks of Laguna Tools, Inc. All rights reserved.