



## DAKE VERTICAL BAND SAW

# Model V-26 E

### INSTRUCTION MANUAL



Please record your saws information

		<b>VERTICAL BANDSAW</b>	
MODEL	V-26 E	MOTOR	2.2 KW
WELDER	4.2 KVA	CONTROL VOLT	110 V
VOLTAGE	220 V	TORQUE MOTOR	0.01 KW
		FREQUENCY	60 Hz
SER. NO	<input type="text"/>	DATE	<input type="text"/>
<a href="http://www.dakecorp.com">www.dakecorp.com</a>			

DAKE (Division of JSJ)

724 Robbins Road

Grand Haven, Michigan 49417

616.842.7110 Phone 800-937-3253

616.842.0859 Fax 800-846-3253

Web: [www.dakecorp.com](http://www.dakecorp.com)

E-mail : [customerservice@dakecorp.com](mailto:customerservice@dakecorp.com)

[technicalsupport@dakecorp.com](mailto:technicalsupport@dakecorp.com)

Revision: R01 V01 04/23/2026

## DAKE V-26E TABLE OF CONTENTS

Forward .....	2-3
Installation and set up.....	3-4
Specifications .....	4-5
Operational Controls .....	6-8
Auto-Feed Table .....	8-9
Operation: Blade installation ... ..	9
Blade Tracking.....	10
Guide Post Adjustment.....	10
Guide Adjustment / Holder and Guide.....	11-12
Blade Selection / Type of Blades .....	12-13
Tooth Shapes .....	13
Set Types .....	13
Blade Selection Chart .....	14
Saw Speed & Pitch Selector .....	15
Welder Operation .....	16
Blade Cutting / Tooth Spacing.....	16
Welding of the Blade .....	17
Annealing (Carbon).....	17
Annealing (Bi-Metal) .....	18
Blade Dressing (Grinding) .....	18
Weld Inspection .....	19
Blade Weld Trouble Shooting .....	19-20
Trouble Shooting Chart / Saw /Blade / Cutting .....	20-22
Maintenance.....	22
Exploded Diagrams and Parts Lists .....	23-27
Electrical Drawing .....	28-30
Warning / Safety Labels .....	31
Circle Cutting Attachment Installation and Set Up.....	32-33

## FOREWORD

First of all, we would like to take this opportunity to thank you for selecting our Dake V-26 E model vertical Bandsaw.

As you know, the vertical bandsaw is a universal saw for contour cutting. Blade selection is important and by choosing the right blade, you can make most any pattern cutting on most any material with this machine. However, the most important thing is to realize how to operate it in a safe and correct way and how to maintain it.

We have tried to supply you all the information about these. Please be sure to look through all the contents in this manual so that you may obtain the maximum efficiency and the longest machine life with minimum expense.

The specifications and information in this manual were current at the time this manual was approved for printing. Dake, whose policy is one of continuous improvement, reserves the right, however, to change specifications or design at any time without incurring obligations.

Always include the part number, model number, and parts description, for parts orders or correspondence concerning your bandsaw, so we can supply you a rapidly after-sales service.

### **▲WARNING**

1. Read the operator's manual carefully. Learn the tools applications and limitations, as well as the specific potential hazards peculiar to it.
2. Always wear approved safety glasses/face shields while using this machine.
3. Make certain the machine is properly grounded.
4. Before operating the machine, remove tie, rings, watches, other jewelry, and roll up sleeves above the elbows. Remove all loose clothing and confine long hair. DO NOT wear gloves when operating.
5. Keep the floor around the machine clean and free of scrap material, oil and grease.
6. Keep machine guards in place at all times when the machine is in use. If removed for maintenance purposes, use extreme caution and replace the guards immediately.
7. DO NOT over reach. Maintain a balanced stance at all times so that you do not fall or lean against blades or other moving parts.
8. Use only sharp blades. Dull blades are dangerous.
9. Make all machine adjustments or maintenance with the machine unplugged from the power source.
10. Use the right tool. Don't force a tool or attachment to do a job which it was not designed for.

11. DO NOT make cuts requiring more power than is available on the machine.
12. Replace warning labels if they become obscured or removed.
13. Make certain the motor switch is in the OFF position before connecting the machine to power.
14. Give your work undivided attention. Looking around, carrying on a conversation. And “horse-play” is careless acts that can result in serious injury.
15. Make a habit of checking to see that keys and adjusting wrenches are removed before turning on the machine.
16. Keep visitors a safe distance from the work area.
17. Use recommended accessories; improper accessories may be hazardous.
18. Never place hands directly in line with the saw blade.
19. Always use push sticks when cutting small material.
20. Raise or lower the blade guide only when the machine has been turned off and the blade has stopped moving.
21. Read and understand warnings posted on the machine.
22. DO NOT use attachments for any other purpose than for what they were designed for.
23. Failure to comply with all of these warnings could lead to serious injury.

## INSTALLATION

### **WARNING!!!**

**The machine table must NOT be used as a lifting point. Damage to the saw could occur.**

**UNLOADING:** Remove the shrink-wrap covering the machine, careful not to damage painted surfaces. **Carefully inspect the machine for physical damage. If damage is noted, notify the truck line at once. They may require inspection, and that a claim be filed.** Check that all standard accessories are with the machine. Some accessories may be boxed or placed behind the rear access door. The band saw is provided with a lifting eye that is screwed into the top of the machine. This lifting eye may be located in the rear compartment.

Particular care should be taken in selecting areas of the machine for handling, as electrical components and adjustment knobs can be marked up or damaged. Remove the mounting bolts holding the machine to the skid, using the lifting eye, remove the machine from the skid and set in designated area.

## CLEANING

1. Remove anti-rust oil.
2. Remove the coating with a clean brush applied with appropriate solvent.
3. When the coating has been softened, remove it with clean rag.

## POWER SUPPLY

1. Shut off the main power switch before connecting cable.
2. Check motor voltage against supply voltage.
3. Make sure the power supply is connected to comply with the local safety regulations.
4. Your saw may be pre-wired with a power cable attached. This cable can be hard wired or the preferred method of installing a properly rated quick disconnect.
5. The leads connect to L1, L2, and L3 and ground. The bandsaw must be grounded.
6. Check that the blade is running in the correct clockwise direction. If the blade runs backwards, disconnect the power. Then reverse any two of the three L1, L2, and L3 leads. Do not reverse the ground.

### ▲ WARNING

**All electrical connections must be done by a qualified electrician. Failure to comply may cause serious injury!**

**All adjustment or repairs must be done with the machine disconnected from the power source. Failure to comply may result in serious injury!**

## SPECIFICATIONS

Specification	Details
Model	Model V-26 E
Capacity	26 × 14 inch
Blade Speed	50 ~ 5000 ft/min
Blade Length	185 $\frac{3}{8}$ inch
Blade Width Capacity	1 inch
Band Wheel Diameter	26 $\frac{1}{4}$ inch
Table Force	80 kgcm max.
Table Speed (No Load)	Forward 12" in 28 seconds, Reverse 12" in 24 seconds
Table Size	23 $\frac{1}{2}$ × 27 $\frac{1}{2}$ inch
Table Tilt	Right / Left -12°
Table Height	38 $\frac{1}{2}$ inch
Table Stroke	12 inch
Main Drive Motor	220V ±10%, 3 Phase, 60Hz, 2.25 kW
Grinder Motor	110V ±10%, 1 Phase, 50/60Hz, 0.04 kW
Torque Motor	110V, 1 Phase, 50/60Hz, 0.01 kW
Blade Welder Capacity	4.2 kVA, .006 ~ .75 inch (6 ~ 19 mm)
Dimensions	52 (L) × 31 (W) × 87 (H) inch
Machine Weight	1500 lbs

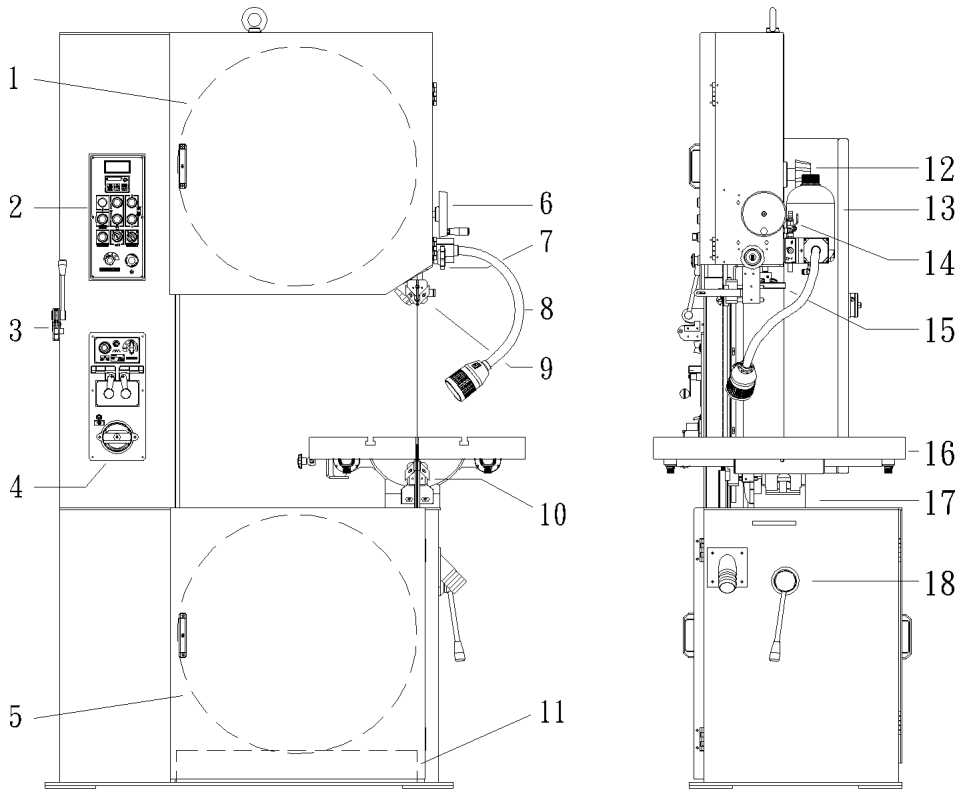
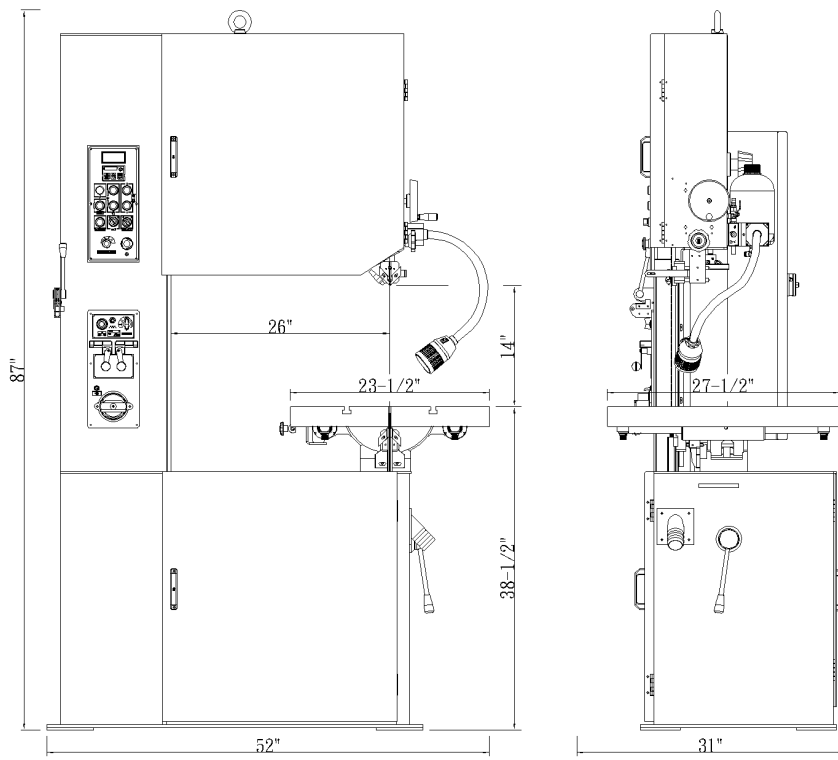

1	Upper Wheel	12	Upper Wheel Tilt Adjuster
2	Control Panel	13	Spraying Bottle
3	Blade Shear	14	Spraying Air Inlet
4	Welder	15	Blade Tension Hand Wheel
5	Lower Wheel	16	Work Table
6	Post Elevating Hand Wheel	17	Table Support Housing
7	Guide Post Locking Knob	18	Low/High Range Shift Lever
8	Work Lamp		
9	Blade Guide Support, Upper		
10	Blade Guide Support, Lower		
11	Chip Collector		

## ▲CONTROLS

### **Blade Speed –**

Blade Speed: 50 ~ 5000 F/min.

The control knob is on the inverter panel, turn clock wise to increase the blade speed.

Blade speed shows in HZ on inverter panel, shows in F/min on digital readout.

### **Low/High Range Shift Lever –**

Located on right side of machine base.

To shift into low-speed range: Open the lower door, slightly rotate the lower wheel clockwise by left hand, while shift the lever toward the front of machine by right hand.

To shift into high-speed range: Open the rear door, slightly rotate the pulley clockwise by right hand, while shift the lever toward the back of machine by left hand. It will be lock once successfully shift into the other range.

Caution: Adjust only when machine is turn off.

### **Digital Readout –**

Located on the control panel. Indicates blade speed per minute. Note: When starting up or changing speed, allow time for the readout to stabilize to the new setting.

### **Guide Post Locking Knob –**

Located on right side of upper frame. Turn counter-clockwise to loosen and clockwise to tighten.

### **Post Elevating Hand Wheel–**

Located on the upper right side of the saw. Turn clockwise to raise the blade guide assembly. Turn counter-clockwise to lower.

**Work Lamp Switch –** Turn lamp on and off.

### **Blade Shear Lever –**

Located on upper left-hand side of the column. Up position allows increase insertion of the blade into the shear. Pull lever downward to cut the blade.

### **Weld Button –**

Located on blade welder panel. Depress and hold to start welding. Shuts off automatically when weld is done. Release when weld is completed.

### **Anneal Button –**

Located on blade welder panel. Depress and hold to anneal blade, release to stop.

### **Blade Clamp Pressure Knob –**

Located on blade welder panel found the front of the column. Sets pressure for different width of blades.

### **Blade Clamps –**

Located on blade welder panel found the front of the column. DOWN position allows insertion of blade into clamp. Up position locks blade.

### **Blade Tension Hand Wheel –**

Located on underside of upper frame. Turn clockwise to tension blade; counter-clockwise to release tension on blade.

### **Blade Tracking Hand Wheel –**

Located at the upper rear of the saw. Turn clockwise to track blade toward front of the blade wheel Turn counter-clockwise to track blade toward rear of the blade wheel.

### **Table Tilt Mechanism –**

Located under worktable. To tilt table left or right, loosen hex cap screws at rear of mechanism.

### **Key Lock Switch –**

Turn to 12 o'clock position and remove key to lock out power from the control panel.

### **Power indicator Light –**

Indicates that power to the control panel is on.

### **Main Motor Start Switch –**

Depress to start bandsaw.

### **Main Motor Stop Switch –**

Depress to stop bandsaw.

### **Grinder Toggle Switch –**

Located on the blade welder panel found on columns front. Flip switch up to start grinder; flip down to stop grinder. This motor has temperature protection which will turn off the power automatically when the motor is over-heating. Motor will reset once it cools down.

**Grinder Motor Start Switch –** Depress to start grinder motor.

**Grinder Motor Stop Switch –** Depress to stop grinder motor.

### **Emergency Stop Switch –**

Press to stop machine. Turn knob 90° to reset.

screws at the rear of the mechanism. Always tighten table bolts before operating the saw

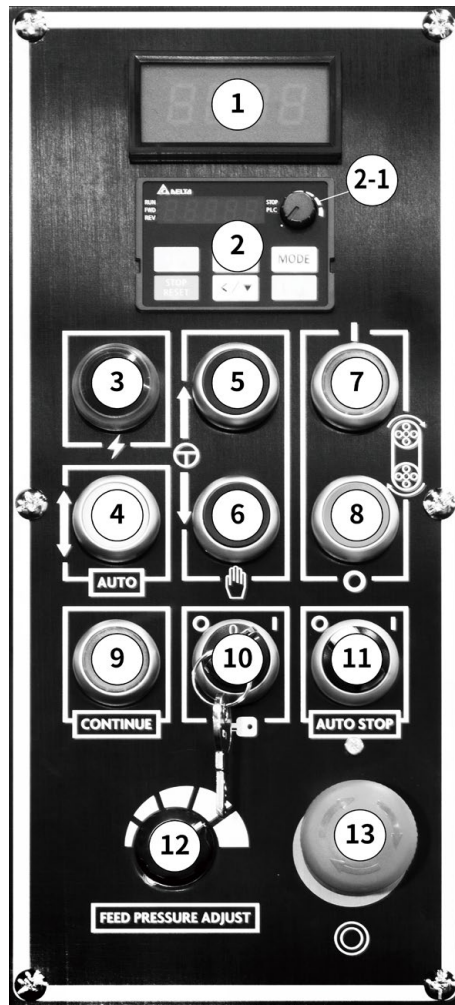

### Control Panel:

**1 - Digital Readout** - Shows blade speed in feet per minute. Allow time to stabilize after startup or speed changes.

**2 - Inverter Control Panel** - Displays inverter data and controls main motor speed.

**2-1 - Blade Speed Adjusting Knob** - Located on inverter panel; turn clockwise to increase speed.

**3 - Power Indicator Light** - Indicates power is on to the control panel.

**4 - Automatic Cutting Switch** - Starts automatic forward and reverse table travel within set limits.

**5 - Table Manual Forward Switch** - Press to move table forward; release to stop.

**6 - Table Manual Reverse Switch** - Press to move table in reverse; release to stop.

**7 - Main Motor Start Switch** - Press to start the bandsaw.

**8 - Main Motor Stop Switch** - Press to stop the bandsaw.

**9 - Continue Cutting Select Switch** - Turn ON for continuous cutting operation.

**10 - Key Lock Switch** - Turn key to 12 o'clock and remove to lock out control panel power.

**12 - Table Feed Pressure Selector** - Adjusts feed pressure; rotate from 9 o'clock (minimum) to 3 o'clock (maximum).

**13 - Emergency Stop Switch** - Press to stop machine immediately; turn knob 90° to reset.

### MANUAL CUTTING, TABLE STATIONARY

1. Adjust table all the way forward
2. Make sure "Auto-stop" is off.
3. Depress the motor start button
4. Adjust your blade speed.
5. Begin free hand cutting.

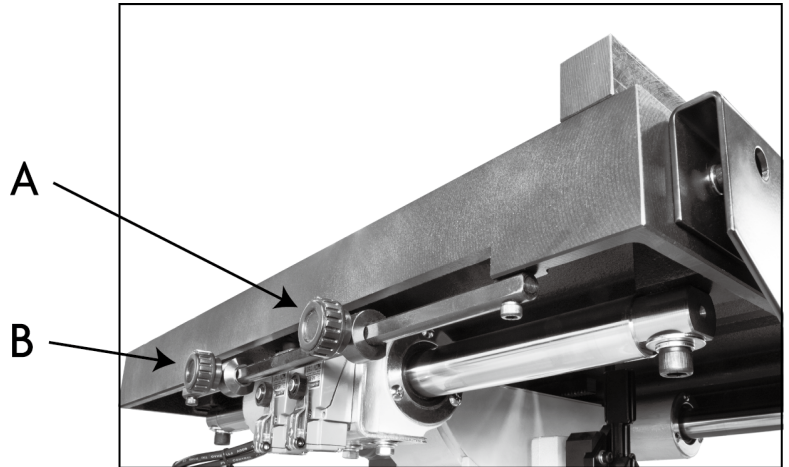

### AUTOMATIC CUTTING

Please make sure that the "Auto Stop" switch is in the "**OFF**" position before making this adjustment.

1. Turn "pressure selector knob" all the way to the maximum. (3 o'clock setting)
2. Depress manual forward and reverse buttons to make table travel. Adjust limits as follows.
3. Adjust the forward limit switch to the position (B) where you want the cut to stop. Adjust knob to just trip the limit switch.
4. Adjust the reverse limit switch to the position (A) where you want the cut to start. Adjust knob to just trip limit switch.
5. Adjust table to the start position, load material, set "pressure selector knob" to the minimum (9 o'clock) position that forces the table travel to start at a slow rate
6. Depress "machine start switch". (Adjust blade speed if needed) Using the manual reverse switch run the blade up to the material.
7. Depress "automatic" button, to make the table travel and slowly start cutting the work piece. Adjust to proper cutting pressure. Adjust "pressure selecting knob" to the position where the work is being cut safely and efficiently.
8. At the end of the cut the blade will keep running and back itself out of the cut. Shut the blade off with main motor off button.
9. To stop the blade at the end of cut switch "Auto Stop switch on when the cut starts. Remove piece and turn off Auto Stop. Blade and table movement will shut off at the end of the cut.

### CONTINUOUS CUTTING

Set up stops as mentioned above. Depress "continuous cutting switch", this will provide a

continuously cutting cycle for light material.

### SINGLE PIECE CUTTING

Switch on “automatic stop selector” knob when the saw is cutting. Machine will stop automatically after the cut is finished.

#### ▲NOTE

Depress “manual-reverse” button to back the work piece from the blade if there is any damage or binding to the blade while cutting, or when table travel set up needs adjusting. However, be sure to adjust feeding pressure lower when reversing out of a cut, to resume the cut the work piece cut should be close to the blade before you start to feed the table again. Do not start blade if the teeth are in contact with the material.

“Table Feed Pressure Selector” is just to adjust the pressure of table feed, not for the “feeding speed”.

## OPERATIONS

### BLADE INSTALLATION

1. Install the blade as illustrated through the guides and onto the upper and lower wheels. Replace any guarding that was removed after blade is installed.
2. Adjust blade tension per the tension scale by turning the blade tension adjustment hand wheel. The scale is visible from the rear side.
3. Jog the machine to see if the blade tracks properly, adjust blade tracking by turning the tracking adjuster when it is necessary. (See blade tracking section on next page for further details)

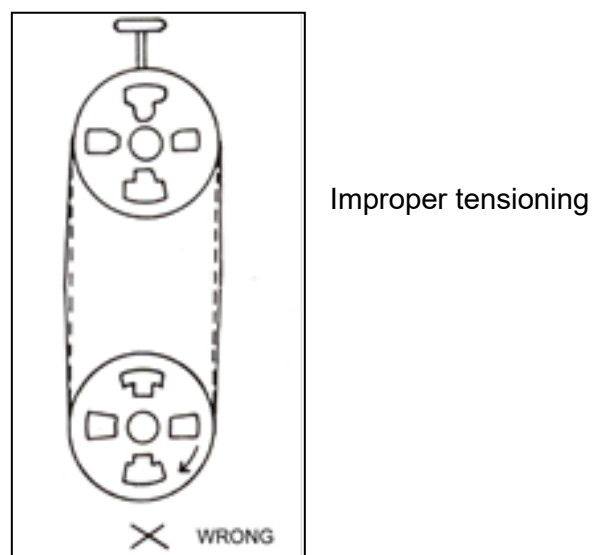
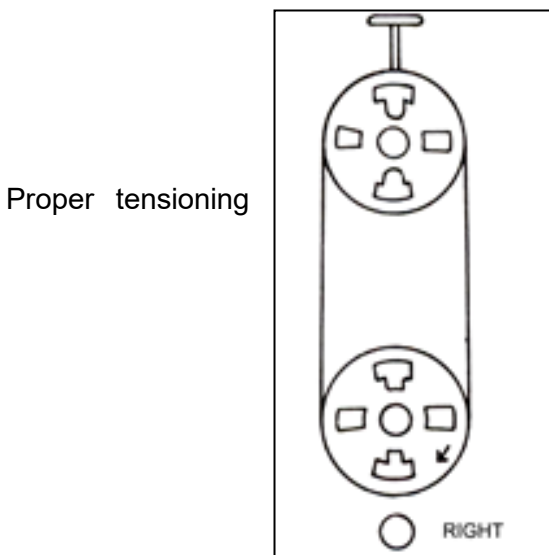

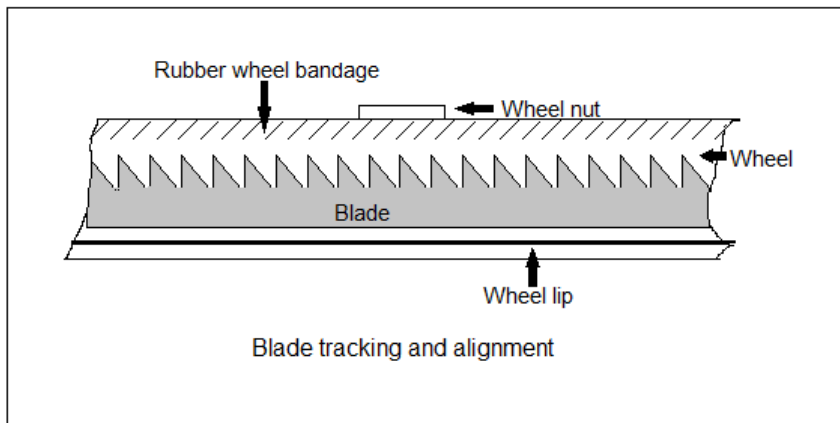

## BLADE TRACKING

Blade tracking may be required from time to time depending on the blade size and tension. Disconnect the machine from the power source and open both blade wheel doors. Shift the high-low gearbox lever into the neutral position. Turn the upper blade wheel by hand while observing blade position on the upper blade wheel to determine if adjustment is necessary:

- Turn blade tracking knob clockwise to track blade toward front of blade wheel.
- Turn counter-clockwise to track blade toward rear of blade wheel. Blade should be tracked as close of the center of the top blade wheel as possible. Do not allow blade to run on the wheel lip.

▲Note: Upper and lower blade guides should be moved away and left loose from the blade while tracking adjustments are being made.

## GUIDE POST ADJUSTING

- Loosen the guide post locking knob. Always support the guide post when loosening the guide post to prevent it from unexpectedly falling. (Figure A next page)
- The height of the upper guide post setting is in relationship to the height of the material. The height between the material and the blade guide end is suggested to be about 1/4". (See figure B illustration on next page)
- Lock the guide post tightly.

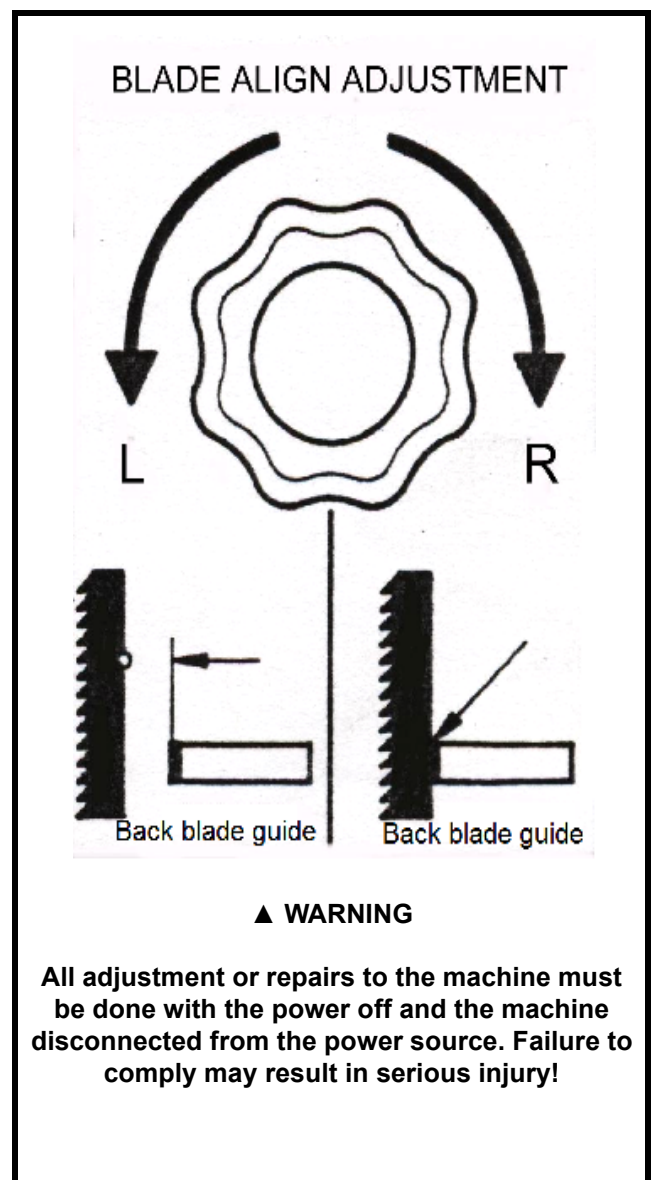

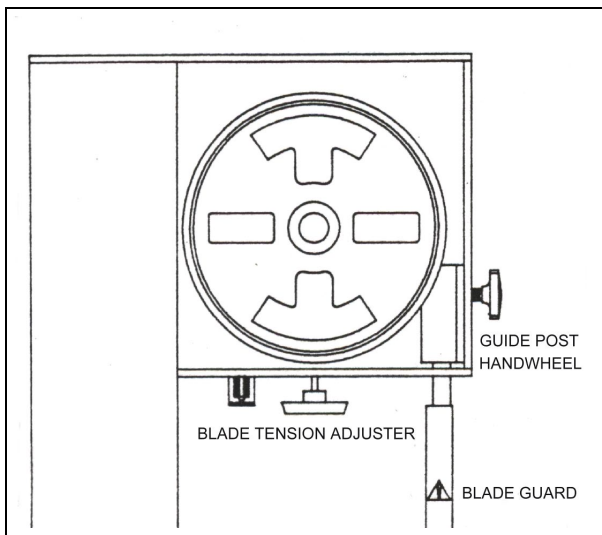

Figure A

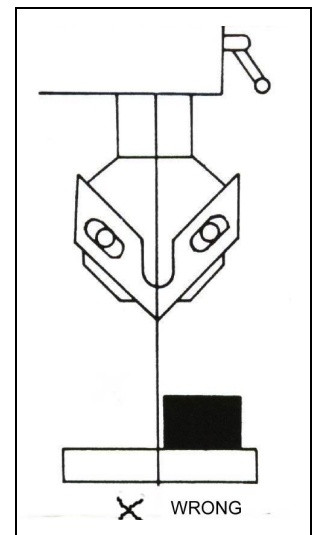
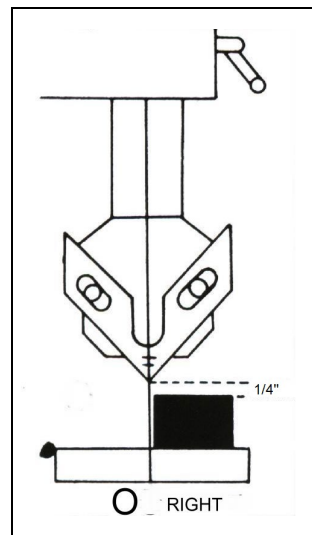
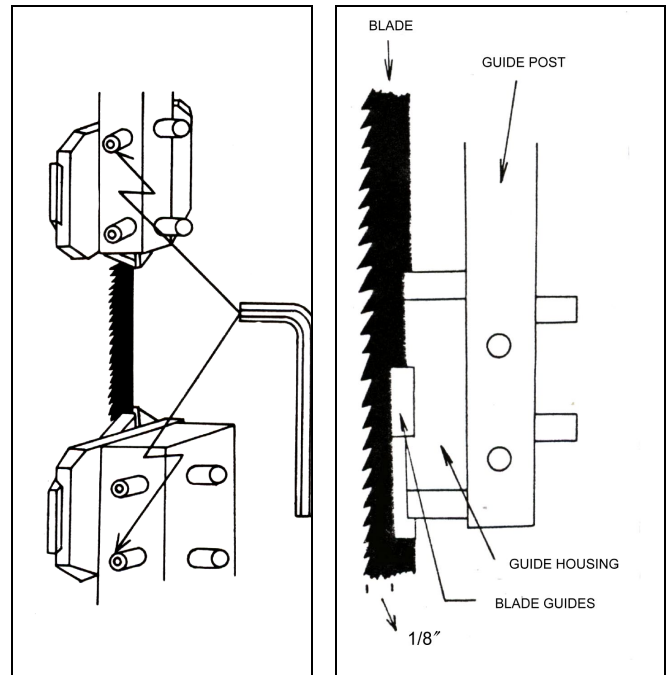

Figure B

▲ It may be necessary to open the blade guides, before you adjust the guide post to allow free movement of the guide post.

### GUIDE HOLDER ADJUSTMENT

1. Loosen the inner hex screws located at the right lower side of guide post with an "L" shaped allen wrench.
2. Adjust the guide holder forward or backward according to the blade width. The front edge of the blade guides must be adjusted about 1/8" behind the blade teeth. (see figure B next page)
3. Tighten the screws securely.



### BLADE GUIDE ADJUSTING

1. Loosen the inner hex screws of the blade guide with an "L" shaped allen wrench.
2. Adjust the blade guides very close to the blade but not touching the guide faces. (approx. thickness of a business card)
3. With blade tight allow guides to ride up to the blade not forcing them off center. Tighten the blade guides securely. (See figure A next page)

**NOTE:** There are a total of four blade guides and two guide holders located above the table and under the table, all to be adjusted to the same position.

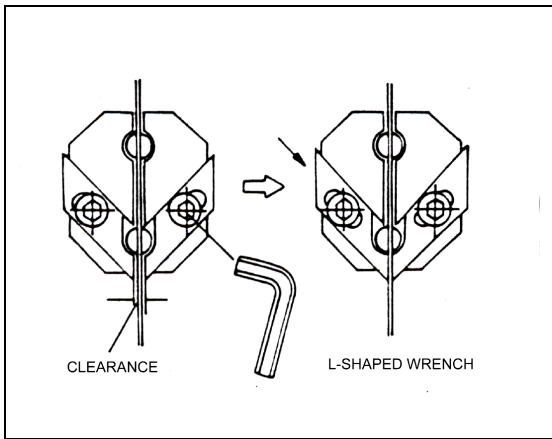

Figure A

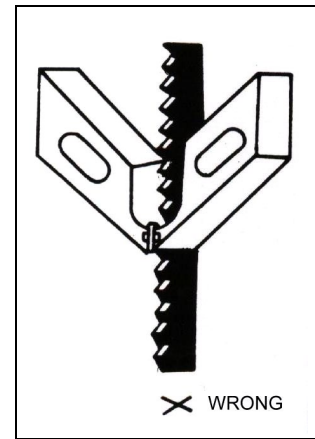
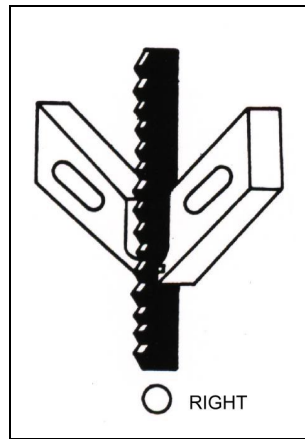
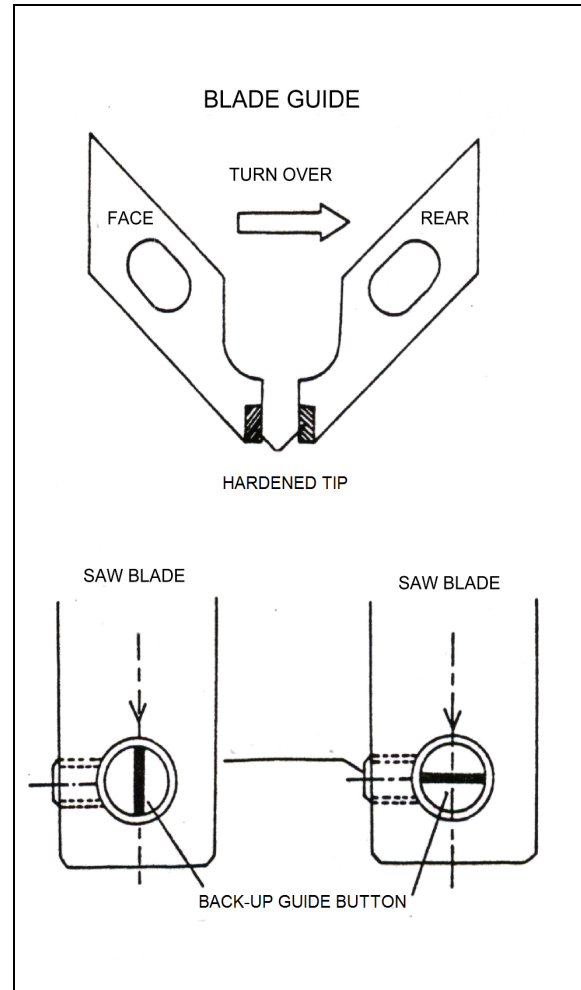

Figure B

The blade guides will wear after time at the front faces. If the blade guides become hard to be properly adjusted, turn the left blade guide over to the right side, as illustrated in the right illustration, and turn the right-side blade guide over to the left side as well. The blade guides can then be used on both sides getting more mileage out of the guides.

The backup blade guide button will wear over time as friction from the saw blade may cause a worn line on its surface. If this is found to happen, loosen the lower guide holder bolt and turn it to rotate the button shaft to change the buttons position on the saw blade.



**▲ CAUTION**

**Blade guide must be properly adjusted or damage may occur to the blade and/or the guides.**

## BLADE SELECTION

To get the most satisfactory work from your saw, it is important to choose a blade that is correct for the work. Blade life, cut straightness, finishing quality and sawing efficiency is all related to the choice of blade. Blade breakage, teeth stripping, crooked cuts, and other common complaints are, in most instances, caused by using the wrong blades. Blades are classified by materials, tooth shapes, and types of set.

## TYPES OF BLADES

Bandsaw blades are available in specific sizes, or in 100 feet coils. They are made from several different metals:

1. Carbon Steel Blade: which are widely used because of their general adaptability for all types of work and the low cost. They are excellent for cutting nonferrous metals and plastics.
2. High-Speed Steel Blade: which resist heat generated in cutting to far greater extent than carbon steel blades. They are best suited for cutting ferrous metals.
3. Alloy Steel Blade: which are tougher and more wear resistant than either of the above. They will cut faster and longer than blades of carbon or high-speed steel.
4. Carbide-Tipped Blade: which are best used for cutting unusual materials such as uranium, titanium, and beryllium. These metals are difficult to cut with other types of blades.

## TOOTH SHAPES

The regular or standard tooth is preferred for all ferrous metals and general-purpose cutting. The skip-tooth blade has widely spaced teeth to provide the added chip clearance needed for cutting softer nonferrous materials. The hook, or saber tooth blades has a  $10^\circ$  undercut which permits better feed and chip removal, it is best for the harder nonferrous alloys.

## SET TYPES

Regular or rake set is generally furnished on saws that have 2 to 24 teeth per inch. These blades have one tooth set to left, one to right, and one unset tooth called a rake. This set is used when material is to be contour cut. Wavy set is furnished on saws that have 8 to 32 teeth per inch. This set has groups of teeth bent alternately to left and right, which greatly reduce the strain on individual teeth. Saws with wavy set are used where tooth breakage is a problem, such as in cutting thin stock or where a variety of work is cut without changing blades.

Of the three common set patterns, only raker and wave are now used in metalworking.

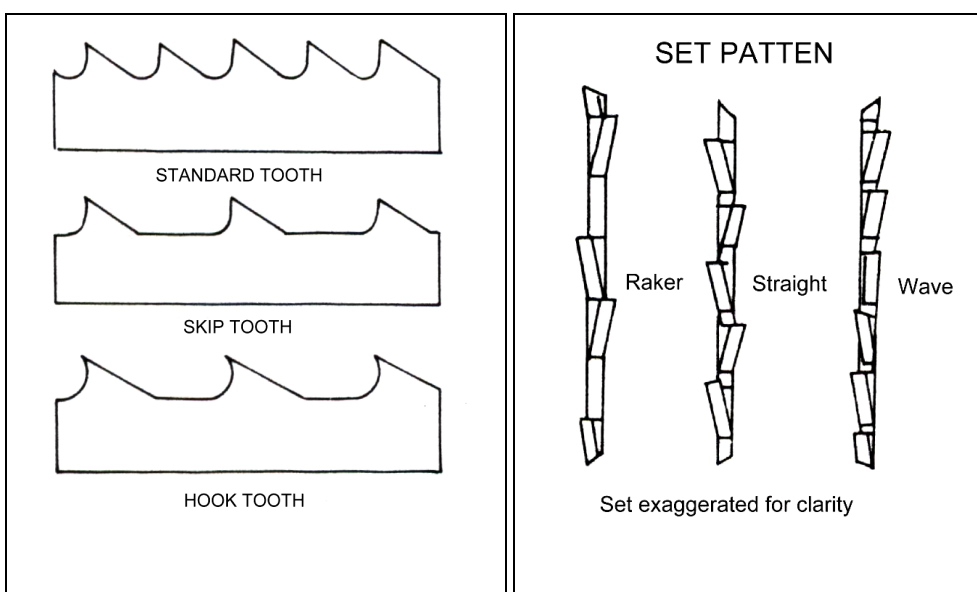

Always use rake set except:

For work of varying cross section use wave set.

When one blade must be used for a range of material sizes use wave set

**▲ PLEASE NOTE THAT CORRECT BLADE SELECTION IS VERY IMPORTANT TO BANDSAW OPERATING AT FULL POTENTIAL. ALWAYS SELECT A BLADE ACCORDING TO THE MATERIAL SHAPE AND THICKNESS OF THE WORK**  
**Always break in the blade per blade manufactures recommendations.**

### SAW BLADE SELECTION

	MATERIAL SHAPE	MATERIAL SHAPE	MATERIAL SHAPE
MATERIAL IN	■	●	○ H A
INCHES	TOOTH SELECTION	TOOTH SELECTION	TOOTH SELECTION
0	14 / 18	14 / 18	14 / 18
.1	14 / 18	14 / 18	14 / 18
.2	14 / 18	14 / 18	14 / 18
.3	10 / 14	14 / 18	10 / 14
.4	8 / 12	10 / 14	8 / 12
.5	8 / 12	8 / 12	6 / 10
.6	6 / 10	8 / 12	5 / 8
.7	6 / 10	6 / 10	5 / 8
.8	5 / 8	6 / 10	5 / 8
.9	5 / 8	5 / 8	5 / 8
1	5 / 8	5 / 8	4 / 6
1 1/4	4 / 6	5 / 8	4 / 6
1 1/2	4 / 6	4 / 6	4 / 6
1 3/4	4 / 6	4 / 6	4 / 6
2	4 / 6	4 / 6	3 / 4
2 1/4	4 / 6	4 / 6	3 / 4
2 1/2	3 / 4	4 / 6	3 / 4
2 3/4	3 / 4	4 / 6	3 / 4
3	3 / 4	3 / 4	3 / 4
3 1/4	3 / 4	3 / 4	3 / 4
3 1/2	3 / 4	3 / 4	3 / 4
3 3/4	3 / 4	3 / 4	2 / 3
4	3 / 4	3 / 4	2 / 3
5	2 / 3	3 / 4	2 / 3
6	2 / 3	3 / 4	2 / 3
7	2 / 3	2 / 3	1.4 / 2.5
8	1.4 / 2.5	2 / 3	1.4 / 2.5
9	1.4 / 2.5	2 / 3	1.4 / 2.5
10	1.4 / 2.5	1.4 / 2.5	1.4 / 2.5
11	1.4 / 2.5	1.4 / 2.5	1.4 / 2.5
12	1.4 / 2.5	1.4 / 2.5	1.4 / 2.5

Please refer to the "Speed & Pitch Selector wheel that is supplied on your saw for speeds and feeds, radius cutting and blade pitch selection.

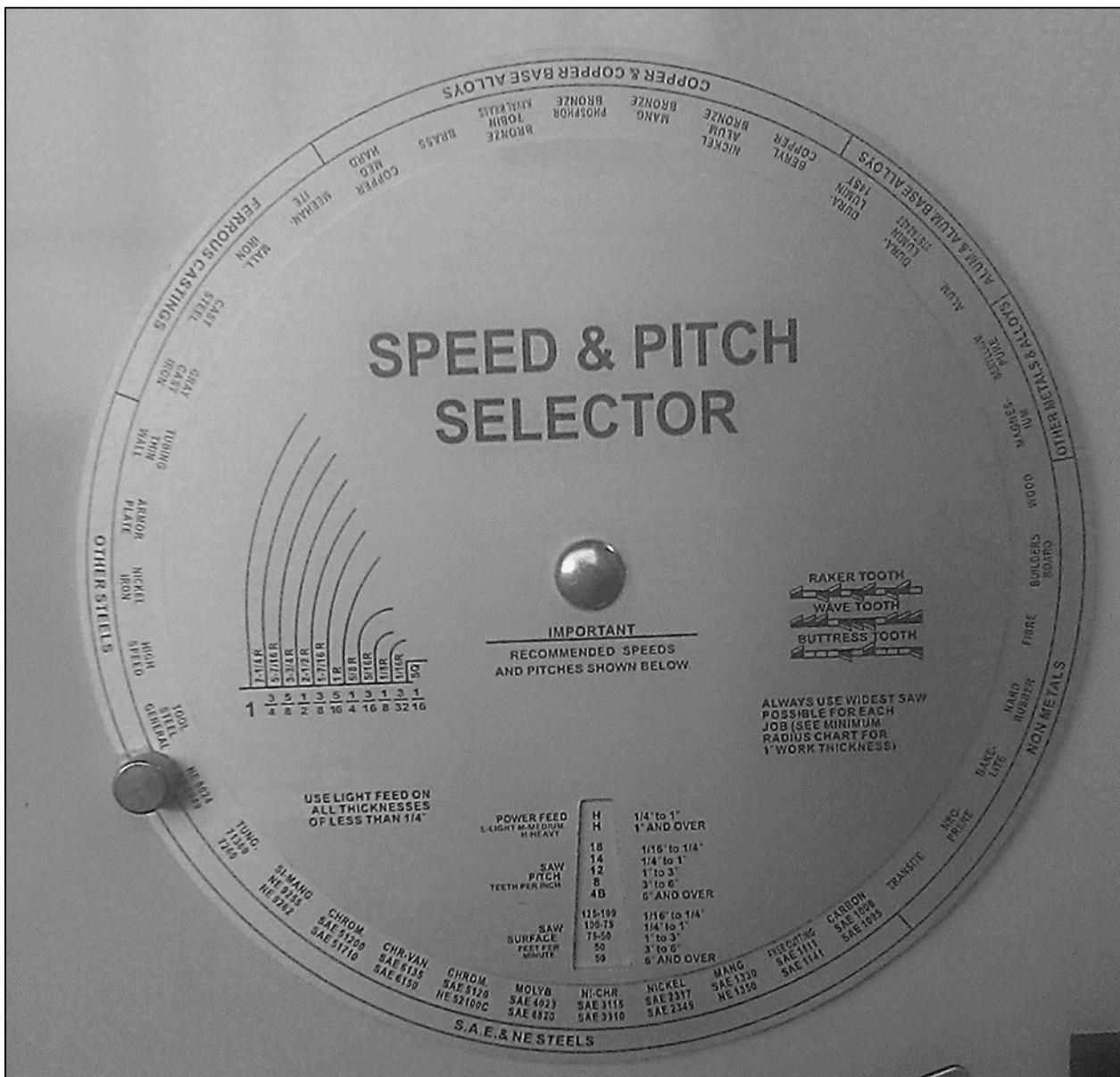

Select saw blades in relationship to the thickness of materials. The following suggestions are a rule of thumb to consider when selecting a blade.

- A. Select a larger pitch blade for a thicker material.
- B. Select a smaller pitch blade for a thinner material.
- C. Use a smaller pitch blade to obtain a smooth cutting surface.
- D. Use a larger pitch blade to obtain a faster cutting speed.
- E. It is important to have different blades for different applications

# WELDER OPERATION

This welder is for occasional use for blade repair and is not intended for welding blades on a regular basis from bulk stock. This welder is best suited for carbon bands but with practice both carbon and bi-metal can also be welded.

## BLADE CUTTING

1. Cut the blade to the length of the machine. Using the blade shear will insure that the blade ends are cut flat, square and smooth.
2. Place the back edge of blade against the square cutting guide of the shear and firmly pull the cutting lever down to shear the blade. Both ends of the blade must be sheared to allow for a good butt weld.
3. Keep the shear blade clean and free from blade end pieces that can get trapped in the shear.

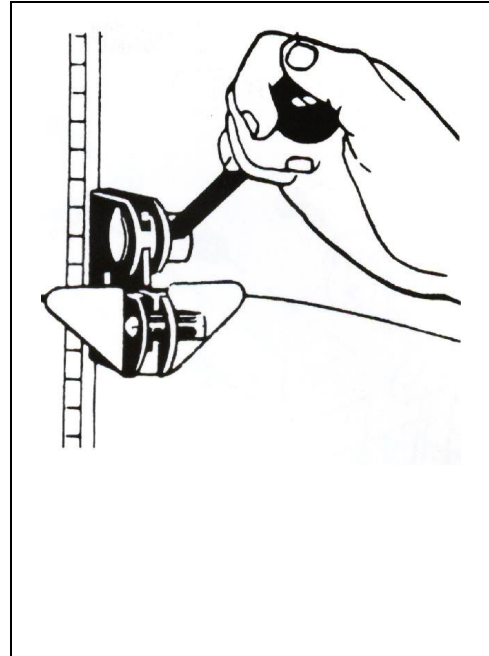

Using the Blade Shear.

## TOOTH SPACING

1. On fine-pitched blades, one or more teeth on each side of the cut must be removed by grinding so that the cross section of the weld area of the blade is uniform. Following these guidelines will help make the teeth uniformly spaced after the weld.

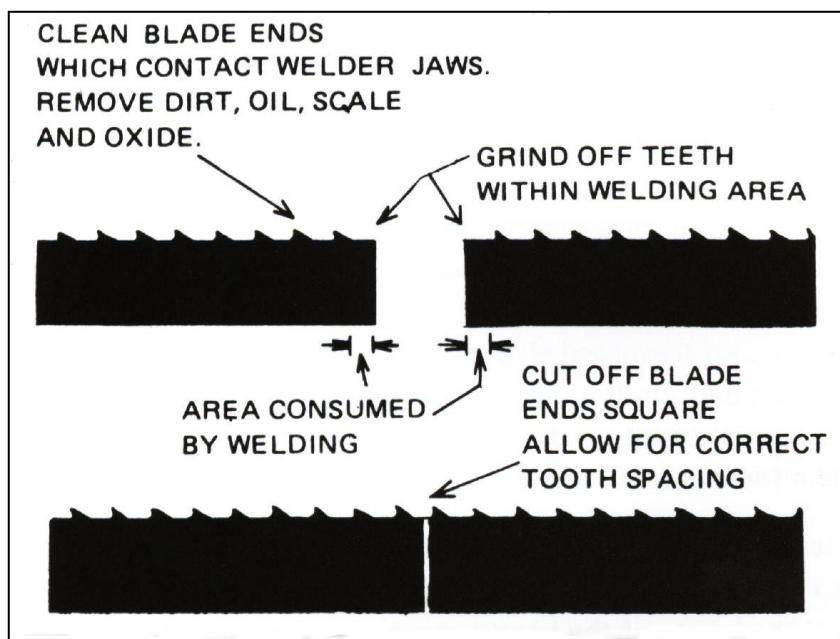

▲ **CAUTION:** If the saw blade is rusty, the rust must be ground off before the blade is welded.

## WELDING

1. Turn pressure knob to "0" position.
2. Butt blade ends together and locate joint in the center between the two electrodes.
3. Set pressure knob to blade width. (Due to the different materials and thickness of blade, please pay especial attention to the pressure adjustment. Thicker the blade higher the pressure setting.)
4. Press and hold welder button. Do not release until the blade joint is "red" hot. The switch is automatic and will shut welder off after a preset time of 3 or 4 seconds and the blade returns to original color. **Note: The weld joint may throw sparks during welding so wear safety glasses and proper apparel.**

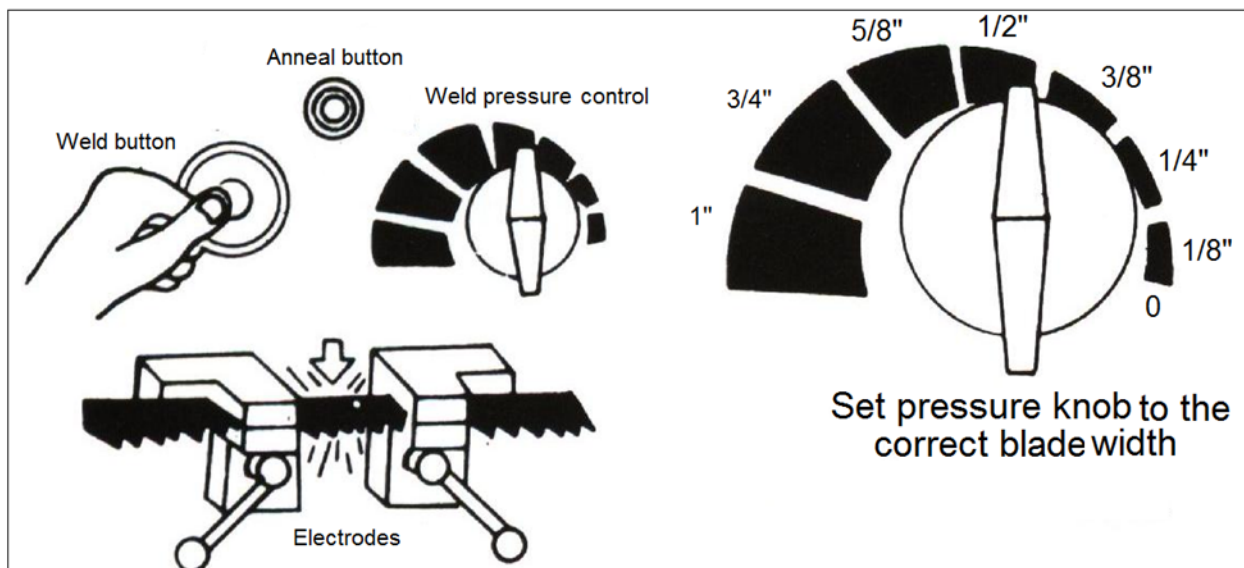

## ANNEALING (Carbon Blades)

1. Turn pressure knob to "0" position.
2. Release blade and center the weld joint at the front of the electrodes. (At the wider part)
3. Press and jog the annealing switch button until the weld is a "dull cherry" to "cherry red" color. Allow the blades to cool slowly by decreasing the jogging frequency.
4. Perform the annealing operations 4 or 5 times, gradually reducing the heat each time.
5. Remove any welding dust or scale from the joint and anneal 2 or 3 more times, successively at lower temperatures. (quicker series of press and release of annealing button)

## ANNEALING (Bi-Metal)

Set up blade for annealing as mentioned above for carbon blades steps 1 & 2.

Heat the band slowly by jogging the annealing switch button until the weld just begins to emit light (this would be the dull red color) or minute puff of smoke. The desired color may not be visible in normal room light. Always shade the weld area with your hand. Cool the weld quickly by releasing the annealing button. Repeat this operation 4 or 5 times.

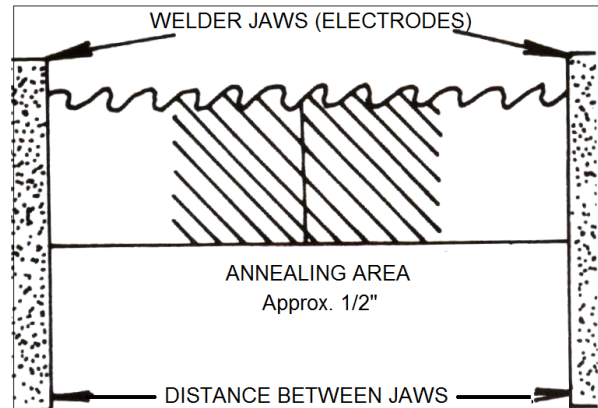

**▲ NOTE: This procedure should be followed both before and after grinding BI-METAL Blades.**

## GRINDING THE WELDED BLADE

### ▲ WARNING

**Keep hands away from rotating grinding wheel. When not in use make, sure wheel is covered with built in cover**

After welding, the blade must be dressed to remove excess metal or flash from the weld. Grind the welded area down to the same thickness as the rest of the band. Handle the blade carefully.

Grind Carefully: do not hit the teeth; or grind deeper than the thickness of the blade; or overheat the weld area. Be sure to remove flash from the back edge of the blade. Any flash or “stub” teeth that project beyond the normal set or height of the other teeth must be ground off.

Anneal the welded area that was ground again. Anneal 2 or 3 times using a lower temperature. (Just as area starts to emit light)

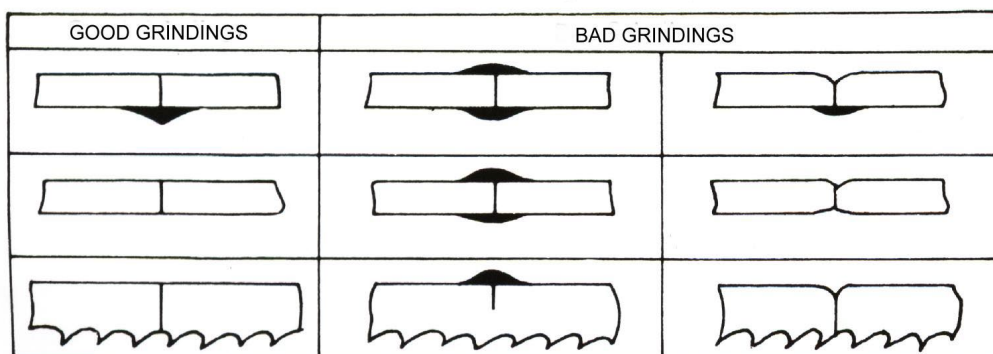

## INSPECION OF THE WELD

When the blade is removed from the welder it should be inspected carefully.

The spacing of the teeth should be uniform and the weld should be located in the center of the gullet. Major jaw misalignment is easily noted at this time from the weld appearance. See the trouble shooting chapter if the weld is imperfect.

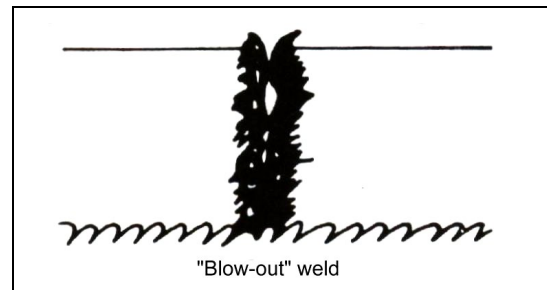
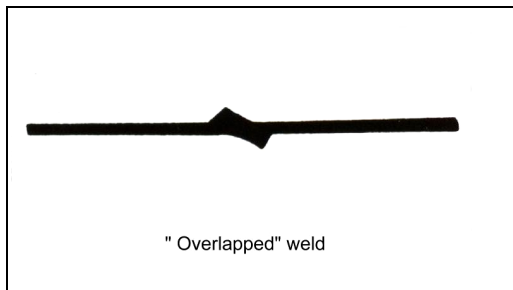
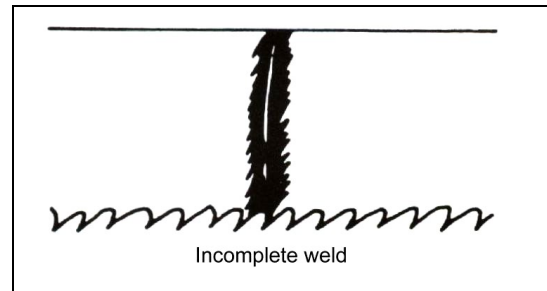
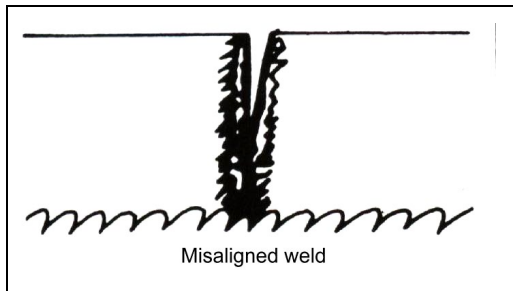
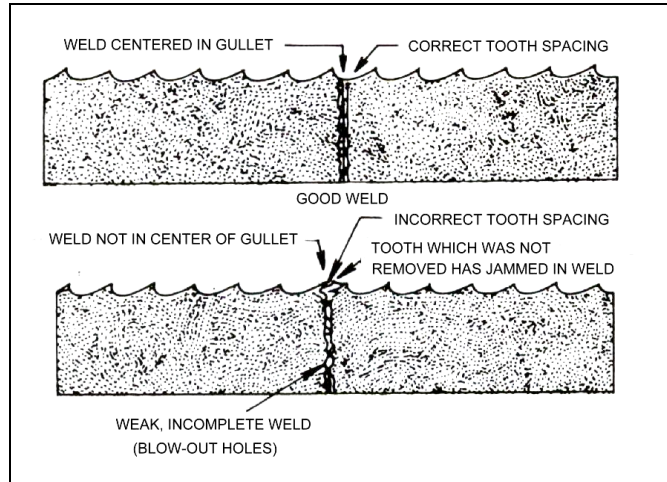

**▲ CAUTION:** This welder is designed for intermittent use. Repeated welding within a short period of time may cause the welder to overheat.

## TROUBLE SHOOTING

### MISALIGNED WELD

- (1) Dirt or scale on jaws or blade.
- (2) Blade ends not cut off square.
- (3) Blade ends not correctly aligned when clamped in jaws.
- (4) Worn jaws or inserts.
- (5) Jaws are not aligned correctly.

## MISALIGNED WELD-BLADE ENDS ARE OVERLAPPED

- (1) Jaw Upset Force Control set for wider blade than used, re-adjust correctly.
- (2) Blade ends or jaws not aligned correctly.

## WELD BREAKS WHEN USED

(Joint is not complete, “blow holes” in joint)

- (1) Weld not annealed correctly.
- (2) Weld has been ground too thin.
- (3) Weak “Incomplete” weld.

## INCOMPLETE WELD (Items 3 – 8 requires welder removal)

- (1) Incorrect Initial Set-Up:
  - (a) Initial jaw gap (weld lever position) not set correctly.
  - (b) Upset force control not set correctly.
- (2) Improper clamping procedures.
- (3) Defective cut-off switch may not break the circuit at end of welding operation.
- (4) Cut-off Switch not adjusted correctly.
- (5) Points of cut-off switch welded together.
- (6) Slide Rod sticking because of rust or dirt. Clean and oil the rod.
- (7) Slide Rod movement obstructed because the stop screw too tight on the Rod.
- (8) Jaw movement obstructed by kinked jaw cable or tangled wires. Bend cable and untangle wires.

## BRITTLE WELDS

Weld has not been annealed correctly; see “Annealing” in operation chapter. Poor annealing can be caused by:

1. Incorrect annealing heat. Bring weld up to correct color as described under “Annealing” in welder operations chapter.
2. Scale or oil on weld can cause poor annealing.

## TROUBLE SHOOTING

PROBLEM	CAUSE	SOLUTIONS
The Weld could not be made, the Jaws do not move	A. The wire connection is poor, the connecting point of welding switch is bad B. The transformer is burnt out C. Some oil is on the blade D. Some rust is on the blade ends E. The adjustment of the welding pressure is incorrect	A. Change the welding switch. B. Change the transformer. C. Remove the oil D. Grind off the rust E. Loosen the adjusting screw that is in center of it
The weld area melts the blade not welds it when welding switch is pushed	A. The welding switch cut off too late B. The Welding Pressure is too weak C. The jaw movement is too slow	A. Screw the welding switch Connecting Nut tight B. Turn the welding pressure adjuster clockwise C. Put some oil on the rear side of the welding lever jaws

The annealing job cannot be made when pushing the anneal button	A. The connection of annealing switch is loose or broken B. The fuse is blown C. The connection of the electrodes to blade is poor	A. Change an anneal switch B. Change a fuse C. Clean electrode surfaces
The grinder is not running when the grinder switch on	A. The grinder motor is defective B. The grinder switch is defective	A. Replace the grinder B. Replace the switch
The blade can not be tightly clamped with the jaw clamps	A. The jaw clamps are burnt or defective B. The lower jaw inserts defective C. The Jaws are burnt or eroded	A. Change clampers B. Change lower jaw Inserts C. Change jaws
The annealing button will not release to neutral position	Some dust or debris around the anneal button restricting movement	Release the anneal button by gently pulling it to the neutral position Clean out any dust or debris
Blade tooth broken	A. Incorrect pitch for the application B. Brittle blade improper annealing C. Inferior blade	A. Select a right pitch blade B. Re-weld and anneal C. Decrease feeding rate D. Change to high quality blade
Blade damaged	A. Brittle blade improper annealing B. Blade tension out of adjustment C. Too Fast feeding D. Blade teeth hitting guides. E. Cannot cut radius without blade twisting.	A. Decrease the annealing temperature B. Adjust blade tension C. Decrease feed rate D. Adjust a proper gap between the blade and the guide insert E. Change to a narrower blade

<b>PROBLEM</b>	<b>CAUSE</b>	<b>SOLUTIONS</b>
Saw blade is twisted	A. Improper weld B. Blade installed in improper way C. Blade tension too loose D. The blade is being over fed	A. Re-weld the blade again B. Set the guide inserts closer C. Increase blade tension D. Decrease the feeding rate when starting the cut E. Use a proper width blade for radius cutting
The sawing direction deviates	A. The blade tooth is not on even or worn unevenly. B. The blade tension is too loose C. The guide post was set too high	A. Make sure a good blade is used without damaged teeth B. Increase blade tension C. Set the guide post to be within a 1/4" of the work D. Decrease feeding rate
Saw blade walks off	A. Blade tension is too loose B. Blade is not tracked properly	A. Increase blade tension B. Adjust the wheel alignment

The blade dulling prematurely	A. The blade speed is too fast B. The selection of blade is improper C. Feeding rate too fast	A. Slow down the blade speed B. Use a proper blade for the application C. Decrease feeding rate
The blade is not cutting straight vertically	A. The blade dull B. The guide post is not properly fixed C. The blade tension is too loose D. The blade is not exactly 90° to the table	A. Change to a new blade B. Fix the guide post properly 1/4" above material C. Increase blade tension D. Adjust it to be 90°
Excessive noise when machine is running	A. The variable speed pulley is damaged C. The saw is not sitting flat on the floor	A. Change a new pulley B. Reposition the machine on a flat even hard floor

## MAINTENANCE

PART OR PLACE TO BE OILDED OR GREASED	TYPE OF OIL OR GREASE	LUBRICATING PERIOD	REMARKS
Bearings	Gear oil	every 6 months	Gear Box:
Guide post sliding part	Grease	weekly	#1350 & #1360
Speed Change handle	Grease	every 6 months	#0600, #0740, #7120 & #7290
Gear and thread	Grease	every 3 months	#7080 & 7110
Variable pulley	Grease	N/A	#9995: <b>V-16 only</b>
Table slide shaft	Machine oil	daily	#1250: E-type only
Upper wheel slide block	Machine oil	monthly	#3100 & #3110
Blade Tension Screw	Grease	monthly	#3110 & #3120
Welder Jaw			(clean up daily)
Rubber Tire			(clean up daily)
Work Table Assembly			(clean up daily)



**GEAR BOX COMPONENT**

0500	1	GEAR BOX
0510	1	GEAR BOX COVER
0520	1	GEAR
0521	1	GAER
0530	1	SCREW NUT
0531	1	SCREW NUT
0540	1	GEAR
0550	1	GEAR SHAFT
0560	1	SHAFT COVER
0570	1	GEAR
0580	1	MAIN SHAFT
0591	1	MAIN SHAFT COVER
0600	1	SPEED CHANGING SHAFT
0610	1	SPEED CHANGING ARM
0611	1	SHAFT STOPPER
0612	1	SPRING
0620	1	SLIDE BLOCK
0630	1	CRUTCH
0631	2	BRASS BRACKET
0632	1	BRASS BRACKET
0700	1	SPEED CHANGING LEVER
0740	1	SHAFT HOUSING
0790	1	SPEED LEVER RIGHT
9220	1	LEVER KNOB
G6008	1	BALL BEARING
G6206	1	BALL BEARING
G6303	1	BALL BEARING
G6304	1	BALL BEARING
L4030	1	OIL SEAL
L5230	1	OIL SEAL
L5840	1	OIL SEAL

**WORK TABLE COMPONENT**

1011	1	WORK TABLE
1015	1	FIXED BLOCK
1021	1	TABLE SUPPORT FRAME
1081	2	BLADE GUARD
1090	1	TABLE SUPPORT HOUSING
1100	1	GUIDE SUPPORT HOUSING
1140	1	HEX HEAD SCREW
1150	1	SLIDER
1151	1	BUSHING
1250	2	TABLE STROKING SHAFT
1230	4	BEARING COVER
1500	1	METER GAUGE
1550	1	RIP FRENCE + LOCK
1600	2	T-BLOCK
1610	1	RIP FENCE SLIDE GUIDE
2500	1	TOROU MOTOR
2501	1	TOROU MOTOR SPEED REDUCER
2510	1	WHEEL GEAR
2520	1	SLIDE GEAR
2530	1	TOROU MOTOR MOUNTING BRACKET
2531	1	TOROU MOTOR PROTECTIVE COVER
2610	1	SET RING SLIDE BAR
2620	2	LIMITED SWITCH SET RING
2650	1	LIMITED SWITCH HOUSING
6165	2	LIMITED SWITCH
9017	2	SET RING LOCKOR
GLM35	4	LINER BEARING
L5235	4	OIL SEAL

**GUIDE POST COMPONENT**

1311	1	GUIDE SUPPORT, UPPER
1312	1	GUIDE SUPPORT, LOWER
1320	4	BLADE GUIDE
1331	1	BLADE STOPER, LONG
1332	1	BLADE STOPER, SHORT
1333	1	BEARING SEAT
1350	1	BLADE GUIDE POST
1351	1	GEAR BAR
1360	1	GUIDE POST HOUSING
1370	1	BLADE GUARD, LEFT
1382	1	BLADE GUARD, RIGHT
1400	2	SPRING
1410	1	SPRING HOUSING
1440	1	POST HOUSING SPRING
1450	1	POST ELEVATING GEAR
1650	1	CIRCLE CUTTING ATTACHMENT
9015	1	GUIDE POST LOCK
9033	1	POST ELEVATE HANDWHEEL
9230	1	HANDLE KNOB
G6201	1	BALL BEARING

**WHEEL COMPONENT**

3010	1	LOWER WHEEL
3020	2	RUBBER TIRE
3030	1	TAPER SLEEVE
3040	1	WHEEL LOCKING NUT
3050	1	UPPER WHEEL
3060	1	UPPER WHEEL LOCK
3080	1	SLIDE BLOCK HOUSING
3090	1	SLIDE BLOCK GUIDE
3100	2	SLIDE BLOCK GUIDE
3110A	1	UPPER WHEEL SLIDER
3116	1	SLIDER SCREW SHAFT
3120	1	WHEEL ELEVATE SHAFT
3121	1	SPRING
3150	1	WASHER
3180	3	INDICATOR RING
3190	1	TENSION INDICATOR
3200	1	WHEEL TILT ADJUSTER
3220	1	WHEEL TILT CONNECTER
3240	1	CONNECTER WASHER
3250	1	CONNECTER HOUSING
7310	1	SPEED READOUT DETECTOR
7330	1	DIGITAL TACHOMETER
8712	1	INDICATOR PLATE
9030	1	HANDWHEEL
9060	1	TILT ADJUST HANDWHEEL
G6305	2	BALL BEARING

**MAIN DRIVE**

2000	1	MAIN DRIVE MOTOR
2010	1	PULLEY (90 A <sup>2</sup> x Ø28)
2020	2	MOTOR POTARY SEAT
2060	1	BELT ADJUSTING SEAT
2070	1	SCREW FOR ADJUSTING SEAT
7071	1	PULLEY (12" A <sup>2</sup> x Ø38)
A71	2	V-BELT, 2010+7071

**SPRAYING SYSTEM COMPONENT**

4180	1	AIR NOZZLE CLIPPER
9501	1	SPRAYING SYSTEM
9502	1	SPRAYING BOTTLE
9508	1	HOZZLE HEAD
9509	1	SPRAY NOZZLE HEAD FIXING

**MAIN BODY & MISCELLANEOUS**

5040	1	UPPER DOOR
5100	1	REAR DOOR, LARGER
5101	1	REAR DOOR, SMALLER
5120	1	LOWER DOOR
8111	1	CONTROL PLATE
8200	1	SPEED AND PITCH SELECTOR (1)
8201	1	SPEED AND PITCH SELECTOR (2)
8202	1	SPEED AND PITCH SELECTOR (3)
8203	1	BRASS BOLT
8204	1	BRASS HANDLE
8205	1	SELECTOR BUSHING
8422	1	GEAR BOX INSTRUCTION
8743	1	TILT INSTRUCTION
9300	2	UPPER DOOR HINGE
9310	6	HINGE
9500	6	SPRING PLATE
9590	3	HANDLE ARM
9602	1	CHIP REMOVAL TUBE
9700	1	INDICATE NEEDLE
9780	1	BRUSHER BRACKET
9790	1	CHIP BRUSHER
9880	1	CHIP COLLECTOR
9900	1	MAGNIFYING GLASS
9999	1	EYE BOLT

**CONTROL SWITCH COMPONENT**

6245	1	VARIABLE TRANSFORMER
6490	1	TIMER
6513	1	BRAKE RESISTOR
6530	1	INVERTER
6531	1	EXTRNSION CABLE
6532	1	INVERTER CONTROL PANEL
6540	1	FILTER
6600	2	PUSH BUTTON, ON, GREEN
6601	1	PUSH BUTTON, ON, WHITE
6602	1	PUSH BUTTON, OFF, RED
6603	2	PUSH BUTTON, ON/OFF, BLACK
6610	1	EMERGENCY SWITCH
6620	3	LIMIT SWITCH
6650	1	KEY SWITCH
6682	1	SELECT SWITCH
6700	1	MAIN POWER SWITCH
6710	1	MAGNETIC SWITCH
6716	3	POWER RELAY
6730	1	CONDENSER
6741	1	PILOT LAMP, GREEN
6745	1	VOLTAGE REDUCER
6752	2	1P FUSE SEAT
6753	2	2P FUSE SAET
6754	1	3P FUSE SAET
6765	1	POWER RELAY
6770	2	WIRE HOUSING
6771	1	GROUND SEAT
6775	1	32P TERMINAL BLOCK
6798	1	ELECTRIC BOX
6799	1	WIRING PLATE
6805	1	WORK LIGHT (LED)

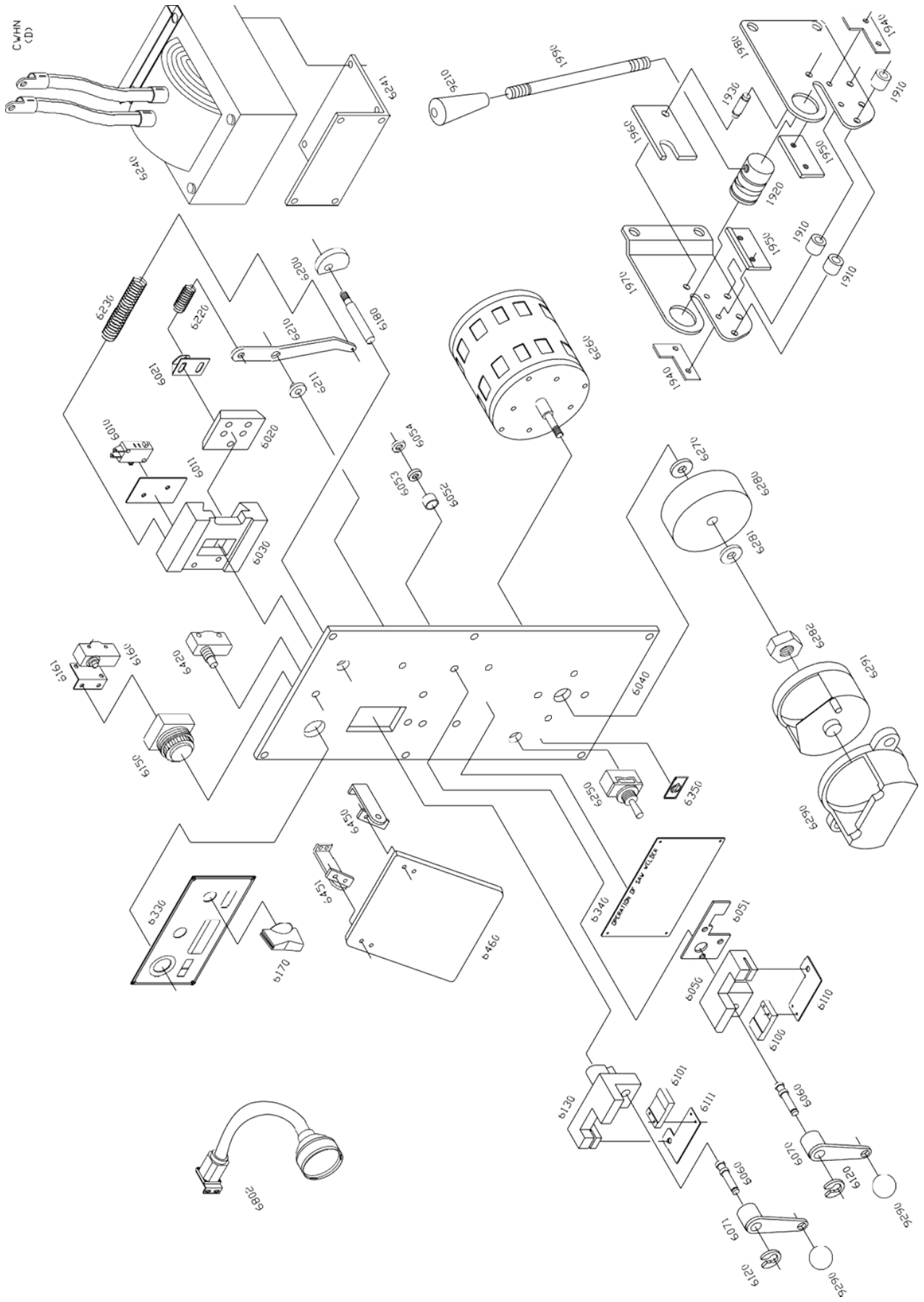

**WELDER COMPONENT**

6010	1 *	LIMIT SWITCH <b>303250</b>
6011	1 *	INSULATOR
6020	1 *	GUIDE BLOCK
6040	1 *	HOUSING
6050	1 *	STATIONARY JAW
6051	1 *	INSULATOR
6052	3 *	INSULATING TUBE
6053	3 *	WASHER, INSULATE
6054	3 *	SPACER
6060	2 *	ECCENTRIC SHAFT
6070	1 *	CLAMP LEVER, RIGHT
6071	1 *	CLAMP LEVER, LEFT
6100	1 *	CLAMP SUPPORT, RIGHT
6101	1 *	CLAMP SUPPORT, LEFT
6110	1 *	CLAMP PLATE, RIGHT
6111	1 *	CLAMP PLATE, LEFT
6120	2 *	CAM
6130	1 *	MOVING JAW
6150	1 *	WELD BUTTON <b>303271</b>
6160	1 *	MICRO SWITCH
6161	1 *	MICRO SWITCH BRACKET
6170	1 *	PRESSURE ADJUST KNOB
6180	1 *	SHAFT
6200	1 *	CAM
6210	1 *	WELD TENSION ARM
6211	1 *	BUSHING
6220	1 *	SPRING, SHORTER
6230	1 *	SPRING, LONGER
6240	1 *	TRANSFORMER (4.2KVA)
6241	1 *	MOUNTING BRACKET (4.2KVA ONLY)
6250	1 *	SWITCH
303787	1 *	GRINDER MOTOR
6270	1 *	SPACER
6280	1 *	GRINDER WHEEL <b>303248</b>
6281	1 *	1/4" WASHER, FLAT
6282	1 *	6 mm-1.0 HEX NUT
6290	1 *	GRINDER GUARD <b>303247</b>
6291	1 *	GRINDER COVER <b>303246</b>
6330	1 *	WELDER NAME PLATE
6340	1 *	INSTRUCTION LABEL
6350	1 *	GRINDER LABEL
6420	1 *	ANNEAL BUTTON <b>303231</b>
6450	1 *	DEFLECTOR BRACKET, RIGHT
6451	1 *	DEFLECTOR BRACKET, LEFT
6460	1 *	SPARK DEFLECTOR
9290	2 *	KNOB <b>303249</b>
<b>WCP</b>	<b>1</b>	<b>42-WELDER ASSEMBLY</b>

**WORK LAMP COMPONENT**

6802	1 *	WORK LAMP COMPONENT <b>303272</b> Bulb MR 16 12v 20W
------	-----	--

**SHEAR COMPONENT**

1910	3 *	SPINDLE BUSHING
1920	1 *	SPINDLE LIFT
1930	1 *	BLADE SHAFT
1940	2 *	VANED IRON PLATE
1950	2 *	LOWER BLADE
1960	1 *	UPPER BLADE
1970	1 *	JOINT PLATE, LEFT
1980	1 *	CHAIN JOINT, RIGHT
1990	1 *	HANDLE BAR
9210	1 *	KNOB
<b>SCP</b>	<b>1</b>	<b>SHEAR COMPLETE 303234</b>

Electric appliance arrangement  
diagram

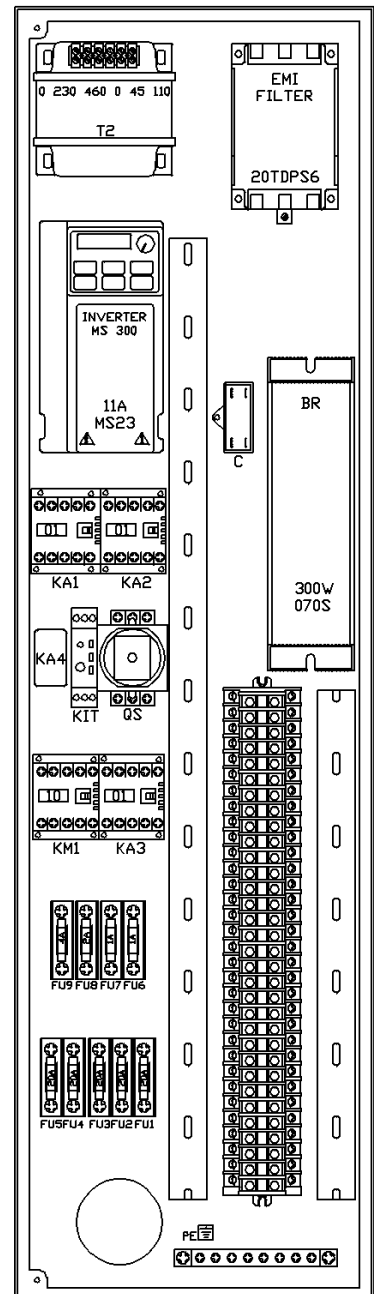

# WIRING DIAGRAM

220V±10% / φ3~60HZ

VBS-2013E
VBS-2614E
VBS-3613E

HIE-ED 2/1

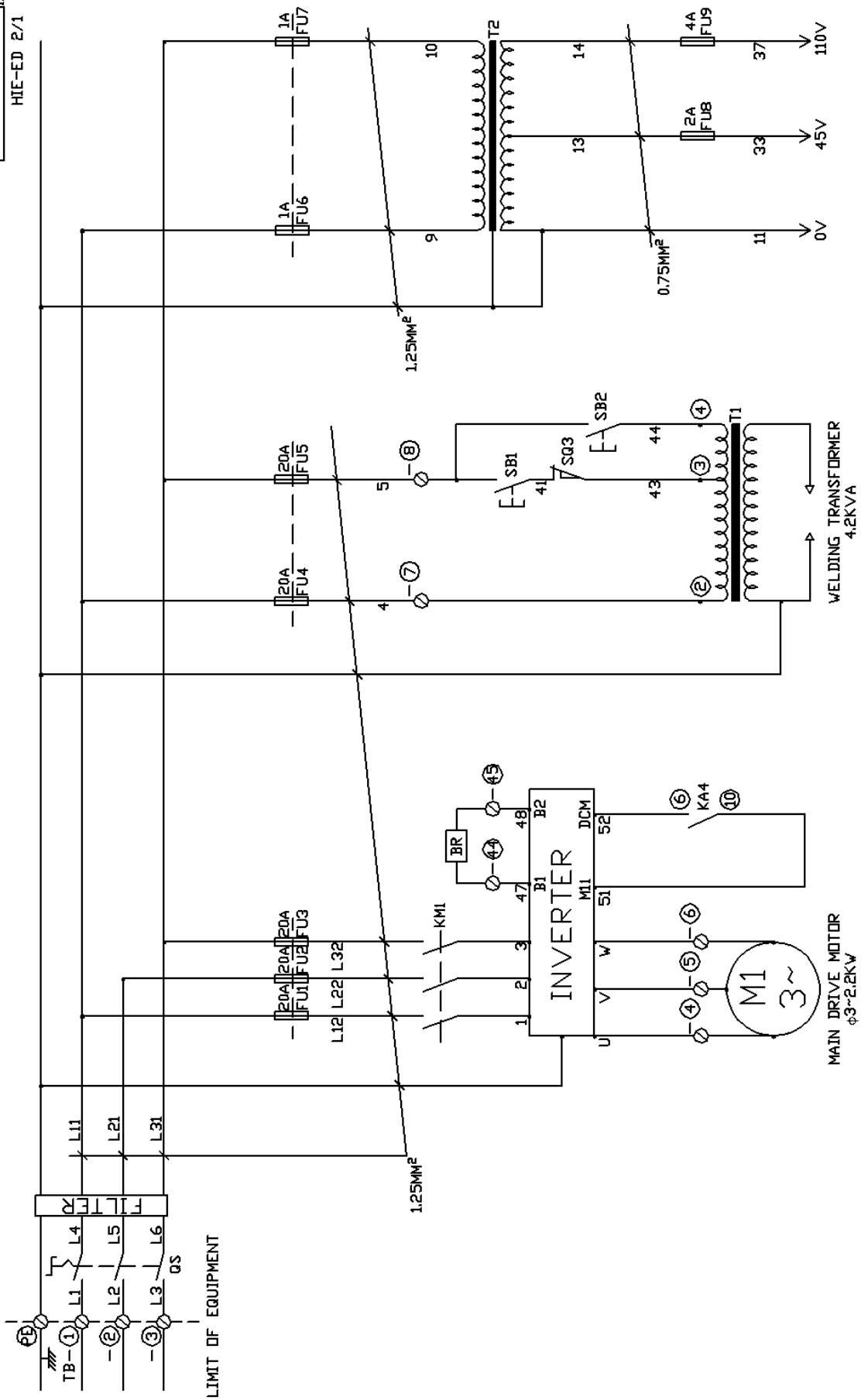

VBS-2013E  
 VBS-2614E  
 VBS-3613E<sub>110V</sub>  
 HIE-ED 2/2

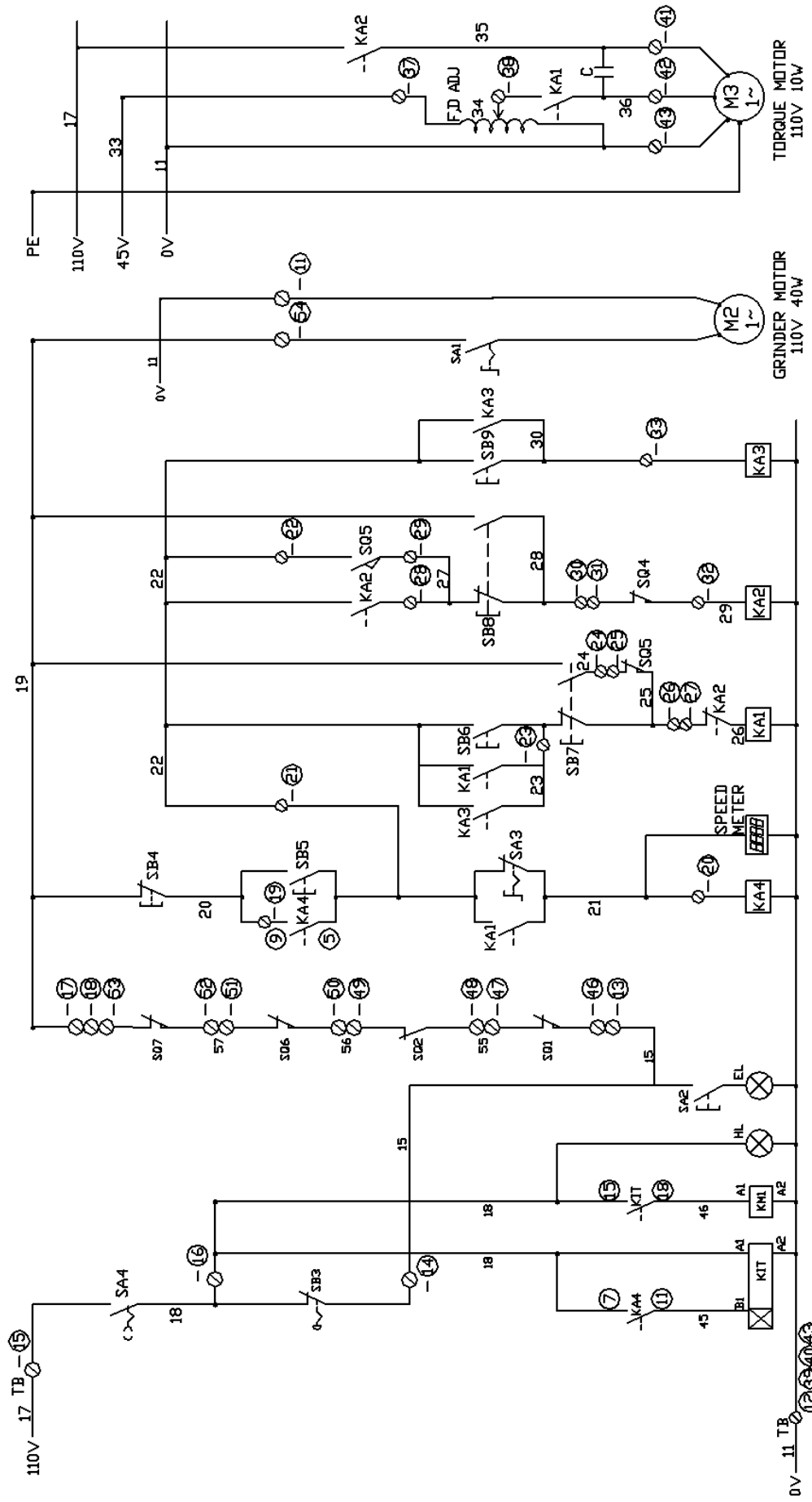

Notice: SQ6 3613 only.

Item	Designation	Technical Data
SB1	WELD ON	15A, 250VAC
SB2	ANNEAL ON	15A, 250VAC
SB3	EMERGENCY STOP	2<<b>> RED
SB4	MAIN MOTOR OFF	1<<a<b>> RED
SB5	MAIN MOTOR ON	1<<a>b> GREEN
SB6	AUTO	1<<a>b> WHITE
SB7	FORWARD	1<<a>+1<b> BLACK
SB8	REVERSE	1<<a>+1<b> BLACK
SB9	CONTINUE GREEN	1<<a>> GREEN
SA3	AUTO STOP	1<a<b>>
SA4	KEY SWITCH	2<<a>>
HL	INDICATOR LIGHT	∅22.2, 110V, GREEN
QS	MAIN SWITCH	U <sub>imp</sub> =6KV U <sub>e</sub> =690VAC
SQ1	LIMIT SWITCH	15A, 250VAC
SQ2	LIMIT SWITCH	15A, 250VAC
SQ3	LIMIT SWITCH	15A, 250VAC
SQ4	LIMIT SWITCH	1<<a>b>, 5A/250VAC
SQ5	LIMIT SWITCH	1<<a>b>, 5A/250VAC
SQ7	LIMIT SWITCH	15A, 250VAC
T1	TRANSFORMER	4.2KVA
T2	TRANSFORMER	150W
KM1	CONTACTOR	U <sub>e</sub> 230V, I <sub>th</sub> 20A, 110V, 50/60HZ
M1	MAIN DRIVE MOTOR	230/460V, 2.25KW 3PHASE, 60HZ
M2	GRINDER MOTOR	110V, 0.04KW 1PHASE, 60HZ
M3	TORQUE MOTOR	110V, 0.01KW 1PHASE, 50/60HZ
KA1	CONTACTOR RELAY	U <sub>e</sub> 230V, I <sub>th</sub> 20A, 110V, 50/60HZ
KA2	CONTACTOR RELAY	U <sub>e</sub> 230V, I <sub>th</sub> 20A, 110V, 50/60HZ
KA3	CONTACTOR RELAY	U <sub>e</sub> 230V, I <sub>th</sub> 20A, 110V, 50/60HZ
KA4	POWER RELAY	6A, 110~120VAC
KIT	TIME RELAY	I <sub>th</sub> e:5A UI:300V, U <sub>lmp</sub> :4KV

Item	Designation	Technical Data
	INVERTER	3PH, 200-240V, 50/60HZ
	EMI FILTER	20A, 3PH, 520VAC, 50/60HZ
BR	BRAKE RESISTOR	0.3KW, 70Ω
EL	WORK LAMP	AC 100~240V, 6W LED
	SPEED METER	110V, 9999M/min
	PHOTO SENSOR	DC 12V
C	CONDENSER	10μF 250VAC, 50/60HZ
F.D ADJ	PRESSURE ADJUST	0 ~ 110V, 2.5 A
TB	TERMINAL BOARD	600V, 20A
FU1	FUSE 10 X 38	120KA/500V~
FU2	FUSE 10 X 38	120KA/500V~
FU3	FUSE 10 X 38	120KA/500V~
FU4	FUSE 10 X 38	120KA/500V~
FU5	FUSE 10 X 38	120KA/500V~
FU6	FUSE 10 X 38	120KA/500V~
FU7	FUSE 10 X 38	120KA/500V~
FU8	FUSE 10 X 38	120KA/500V~
FU9	FUSE 10 X 38	120KA/500V~
CABLE	LIMIT SWITCH & GRINDER MOTOR	0.75 mm <sup>2</sup> x 2C
	CONTROL PLATE	0.75 mm <sup>2</sup> x 20C
	WELDER	2.00 mm <sup>2</sup> x 3C
	MAIN DRIVE MOTOR	2.00 mm <sup>2</sup> x 4C
WIRE	ELECTRICAL BOX	0.75 mm <sup>2</sup> x 1C
	ELECTRICAL BOX	0.75 mm <sup>2</sup> x 1C
	ELECTRICAL BOX	0.75 mm <sup>2</sup> x 1C
	ELECTRICAL BOX	1.25 mm <sup>2</sup> x 1C

**⚠ Warnings**

- Employer is responsible to perform a hazard/PPE assessment before work activity.
- Do not make repairs or adjustments unless you are competent or working under competent supervision. If in doubt consult a qualified technician or engineer
- Only use Dake original parts
- Do not alter this band saw from the original design.
- Lock out Tag out procedures must be followed by authorized employees as per OSHA.

**ELECTRIC** – Electric must be locked out in accordance to OSHA standards.

**WARNING LABELS**



**To the left is the safety Alert symbol.** When you see these safety alert symbols on your band saw, be alert to the potential for personal injury.

**Follow recommended precautions and safe operating practices.**

**Carefully read all safety messages in these instructions and on your band saw safety signs.** Keep safety labels in good condition. Replace missing or damaged safety labels. **This machine is intended to be operated by one person.**



Label 84604



Label 84605

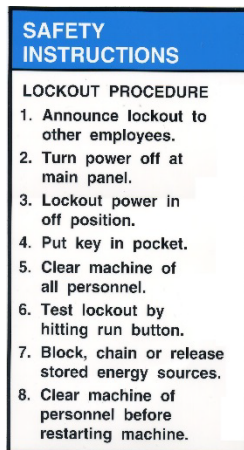

Label 76462



**Label Placement View**

**This machine is wired for 220 volt 3 phase!**

## Circle Cutting Attachment



**CIRCULAR CUTTING ATTACHMENT:**

1. Install the Circular Cutting Attachment. <Figure 1>
2. A. The position of the blade tooth should be opposite to the cutting center at nine o'clock position. <Figure 2>
- B. The height between the object and the blade guide end is suggested to be about 5 mm. <Figure 3>
- C. Use the blade under 8mm width if possible, it will avoid interference. When cut smaller circle, use smaller width blade.
3. A. Measure the cutting radius, set the distance between the blade tooth and the Set Point by the Lock Screws. Loosen the Lock Screw (1) & (2) to adjust the cutting radius. Tighten the Lock Screw (1) & (2) after finish it. <Figure 1, 4 & 6>
- B. Use the Micro Adjust Screw to get the precise cutting radius. Loosen the Lock Screw (1), and then adjust the Micro Adjust Screw. Tighten the Lock Screw (1) after finish it. <Figure 1 & 4>
4. Mark a center point (or drill 5mm hole) and draw a circle on the object. Start to cut from the object nearby until touch the rim, and then fix the Set Point in the object. < Figure 5 & 6 >
5. Rotate the object to finish it. <Figure 6>

